

# SHADOWCLAD® SPECIFICATION & INSTALLATION GUIDE

FOR DIRECT FIX CLADDING

SEPTEMBER 2018

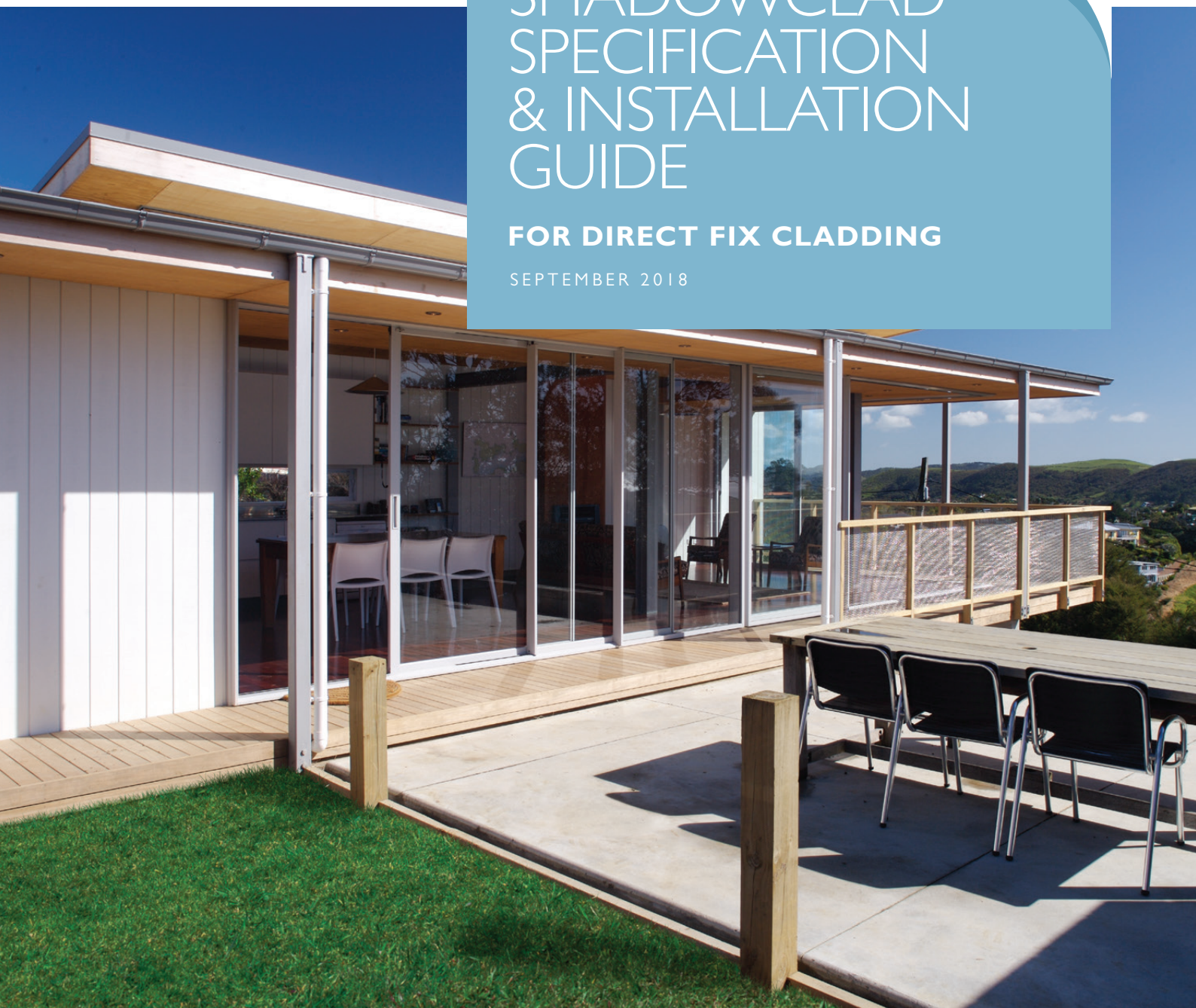

# shadowclad®

DIRECT FIX CONSTRUCTION

## Contents

1.0	Shadowclad® Product Range.....	3
1.1	Technical Information & CAD Details .....	3
1.2	Product Description & Range.....	4
1.3	Building Materials For Use With Shadowclad® (Exterior Cladding).....	8
1.4	Preservative Treatment.....	8
1.5	Sustainability .....	8
1.6	Product Identification.....	9
2.0	Design Considerations.....	9
2.1	Design Responsibility .....	9
2.2	Literature Scope.....	9
2.3	Code Compliance .....	9
2.4	Site & Foundations .....	10
2.5	Ground Clearances .....	10
2.6	Moisture management .....	10
2.7	Wind Loading .....	10
2.8	Durability .....	10
2.9	Textured vs. Smooth Finished Plywood As Exterior Cladding .....	10
2.10	Health & Safety.....	11
2.11	Storage & Handling .....	11
3.0	Installation - Interior Linings .....	11
4.0	Installation – Exterior Cladding .....	12
4.1	Framing – Construction .....	12
4.2	Preparation – Building Underlay.....	12
4.3	Preparation - Direct Fix Construction .....	12
4.4	Sheet Layout .....	13
4.5	Fixings – Fastener Durability.....	13
4.6	Fixings – Fastener Size & Layout .....	14
4.7	Installation Tools for Shadowclad® .....	14
4.8	Shadowclad® Key Installation & Design Points..	15
4.9	Vertical Sheet Joints .....	16
4.10	Horizontal Sheet Joints .....	20
4.11	External Corners.....	22
4.12	Internal Corners.....	23
4.13	Shadowclad® Flashing Junction Points.....	24
4.14	Window Penetrations .....	26
4.15	Wall Penetrations .....	28
4.16	Sheet Clearances.....	32
4.17	Other Details.....	33
5.0	Coating & Application – Exterior Cladding .....	35
5.1	Surface Preparation.....	35
5.2	Coating Application .....	35
5.3	Coating Selection .....	35
5.4	Coating Requirements if run off is used for drinking water.....	36
6.0	Maintenance.....	37
7.0	Frequently Asked Questions .....	38
8.0	Glossary of Terms.....	39
9.0	References & Sources Of Information.....	39
10.0	Limitations .....	40





## I.0 SHADOWCLAD® PRODUCT RANGE

Manufactured by Carter Holt Harvey, Shadowclad® is a range of H3 LOSP treated plywood panels suitable for exterior cladding applications.

Shadowclad is manufactured under a third party audited quality control programme to monitor compliance with AS/NZS 2269 Plywood Structural. All Shadowclad products carry Engineered Wood Products Association of Australasia (EWPA) Joint Accreditation System – Australia and New Zealand (EWPA/JAS-ANZ) certification.

For information relating to Ecoply® structural plywood and applications other than exterior cladding, please contact Carter Holt Harvey Plywood Pty Ltd (CHH Plywood) on 1800 338 463.

Shadowclad products must be competently installed in accordance with good building practice and sound design principles to satisfy the requirements of the Building Code of Australia published as part of the National Construction Code Series 2016, Volume Two, (NCC 2016, Building Code of Australia - Volume Two). This is the responsibility of building owners and the design professionals and builders that they engage. This document contains information, limitations, and cautions regarding the storage, handling, installation, usage, and the maintenance of Shadowclad. However, CHH Plywood assumes no legal liability to you in relation to this information.

### I.1 TECHNICAL INFORMATION & CAD DETAILS

When specifying or installing any Shadowclad product visit [www.shadowclad.com.au](http://www.shadowclad.com.au) to ensure you have current specification material.

**Having trouble installing Shadowclad®? Visit [www.shadowclad.com.au](http://www.shadowclad.com.au) or download the Shadowclad APP to view the installation animations of common Shadowclad junctions.**

#### **Important Notice & Warning**

*While the products in this document possess the characteristics described, no representation is made that the products will be effective in all locations and circumstances. Much depends upon building design, construction practices and the environment in which the products are used. Statements about the attributes and performance characteristics of the products are made on the assumption that the products are properly stored, handled, installed, used and maintained in their relevant application.*

*You should not rely solely on this document when using the products. CHH Plywood recommends obtaining professional building advice which takes into account your particular circumstances and site conditions. CHH Plywood is not involved in, and does not assume responsibility for, the selection, installation or maintenance of our products in situ.*

*Failure to install CHH Plywood in accordance with applicable building regulation requirements and instructions may lead to personal injury, loss or damage, and may adversely affect the performance of the products.*

## 1.2 PRODUCT DESCRIPTION & RANGE

Shadowclad® structural plywood panels are manufactured from radiata pine wood veneers. The veneers are placed at right angles to each other for maximum strength and stability then bonded together with synthetic phenolic (PF) resin to form a strong and permanent Type A bond.

Shadowclad is available in panel sizes 2440/2745 x 1216mm (to provide 1200mm cover) and features a unique textured (bandsawn) appearance which also helps to diffuse UV rays for increased aesthetic performance when exposed to weather.

Shadowclad is available as a Textured or Grooved profile and in either Natural or Ultra finishes.

### Shadowclad® Natural

Shadowclad Natural is an uncoated panel suitable for use with penetrating stains, film forming stains and paint systems. If Shadowclad is left uncoated or is clear coated in exterior applications the long term aesthetics of the board will be significantly reduced. While the product will meet durability and weathertightness requirements for cladding, a high visual appearance will not be achieved in the long term.

### Shadowclad Ultra

Shadowclad Ultra features a factory applied exterior grade performance coating suitable for use with most paint and film forming stain systems. Using a unique powder coating process on the panel face and edges means Ultra panels can be immediately top coated on site, eliminating (in most cases) the need for expensive and time consuming wet primers.

CHH Plywood recommends the use of Shadowclad Ultra where suitable paint or film forming stains are being used.

#### Shadowclad Ultra features:

- High 60-80 microns film build, can be up to 2-3 times thicker than traditional wet primers.
- Continuous powder coated surface forms an effective moisture barrier for a dryer more consistent painting surface.
- Saves time and money as traditional wet primers are not normally required.
- Panel surface, edges and bottom 150mm of sheet factory primed for increased panel durability.
- Once installed Shadowclad Ultra can be exposed to weather for up to 3 months prior to application of finishing coats
- Low volatile organic compound (VOC) coating.

Shadowclad Ultra is available H3 LOSP treated for use as an exterior cladding.

For information on untreated panels for interior wall or ceiling linings, contact CHH Plywood on 1800 338 463.

Shadowclad Ultra is not suitable for use with penetrating stains. The selection, application and maintenance of coatings is the responsibility of the building owners and the professionals that they engage. For advice on specific coating systems and their suitability for use with Shadowclad Ultra, always refer to the coating manufacturer.

**Table 1: Surface Finishes**





Natural		Ultra	
Texture	Groove	Texture	Groove
			
Shadowclad Natural is an uncoated panel suitable for staining and painting.		Shadowclad Ultra features a performance coated surface ready for top coating with paints and film forming stains. It is suitable for use in exterior applications only.	

Table 2: Shadowclad® Product Range

	Texture	Groove
<b>Finish</b>	Natural or Ultra	Natural or Ultra
<b>Sheet Length</b>	2440 and 2745mm	2440 and 2745mm
<b>Width (overall)</b>	1216mm	1216mm
<b>Width (effective)</b>	1200mm	1200mm
<b>Cover/Width Tolerance</b>	+/- 1mm	+/- 1mm
<b>Nominal Thickness</b>	12mm	12mm
<b>Weight (kg/m<sup>2</sup>)</b>	6.6	6.6
<b>R-value (m<sup>2</sup>.C/W)</b>	0.104	0.104
<b>Groove Profile</b>	N/A	9mm wide, 5mm deep at 150mm centres
<b>Edge Profile</b>	Ship lap with weather groove	Ship lap with weather groove
<b>Treatment Available</b>	H3 LOSP (Azole)	H3 LOSP (Azole)

### Shadowclad® Exterior Flashing Range

Manufactured from extruded aluminium or folded from stainless steel, the Shadowclad® flashings range is purpose designed to complement Shadowclad panels used in exterior applications.

Independently tested for weathertightness and compliant with AS/NZS 4284 "Testing of Building Facades". The range includes internal and external angles and Horizontal 'Z' flashings.

**Note: Stainless steel fasteners should not have contact with or pierce aluminium flashings. Where stainless steel fasteners are to pierce flashings, stainless steel flashings should be used.**

Aluminium horizontally installed flashings come in 3600mm lengths and vertically installed angles are available in 3000mm lengths - refer Table 3. Stainless Steel flashings are available in 3000m lengths - refer Table 4.

The information, details and performance statements provided in this guide are based on Shadowclad plywood panels and Shadowclad flashings being used together as a system. CHH Plywood does not recommend that Shadowclad plywood panels be installed with non-CHH Plywood flashings. Flashings not supplied by CHH Plywood must, as a minimum, comply with the performance requirements of the NCC 2016, Building Code of Australia - Volume Two and be compatible for use with H3

treated plywood. It is the Designer's responsibility to ensure that any non-CHH Plywood flashings are fit for purpose and compatible with Shadowclad products and any other building materials or components of the exterior wall.

### Aluminium Flashing Finishes

Shadowclad aluminium flashings are available in either natural anodised finish (silver colour) for immediate installation or mill finished allowing customers to powder coat flashings to any desired colour finish. Please refer to your local powder coating supplier for information.

### Sea Spray Exposure

For coastal areas with high risk of wind blown sea spray salt deposits CHH Plywood recommends the use of stainless steel flashings (and fasteners). Coastal areas with high risk of wind blown sea spray salt deposits are further defined for high or very high environments as defined in notes 3 and 4 of Table 3.5.1.1 a Acceptable Corrosion Protection for Sheet Roofing of the NCC 2016, Building Code of Australia - Volume Two.

See important notice and warning on page 3.

Table 3

## Aluminium

## Shadowclad® Flashings Range

Flashing	Line Drawing	Description	Finish Available	Length (mm)
Internal 90° Angle		Back flashing for internal corners	Natural Anodised	3000
Internal 'W' Angle		'W' back flashing for internal corners providing a flush finish with panels (13mm x 13mm)	Natural Anodised or Mill	3000
Large Internal 'W' Angle		'W' back flashing for internal corners (25mm x 25mm) <b>Design Tip:</b> Use a Large 'W' where a flush junction between the Horizontal 'Z' flashing and corner flashing is desired	Natural Anodised, or Mill	3000
External Box Angle		Box corner for external corners providing a flush finish with panels	Natural Anodised or Mill	3000
Large External Box Angle		Box corner for external corners (25mm x 25mm) <b>Design Tip:</b> Use Large External Box where a flush junction between the Horizontal 'Z' flashing and corner flashing is desired	Natural Anodised, or Mill	3000
Horizontal 'Z' Flashing		Horizontal 'Z' flashing for horizontal joints between panels	Natural Anodised or Mill	3600
Horizontal 'Z' Back Flashing		Back flashing for junction of butt jointed Horizontal 'Z' flashing.	Mill	300

Table 4

Stainless Steel

Shadowclad® Flashings Range

Flashing	Line Drawing	Description	Finish Available	Length (mm)
Internal 90° Angle		Back flashing for internal corners	Stainless Steel	3000
Large Internal 'W' Angle		'W' back flashing for internal corners (25mm x 25mm)	Stainless Steel	3000
Large External Box Angle		Box corner for external corners (25mm x 25mm)	Stainless Steel	3000
Horizontal 'Z' Flashing		Horizontal 'Z' flashing for horizontal joints between panels	Stainless Steel	3000

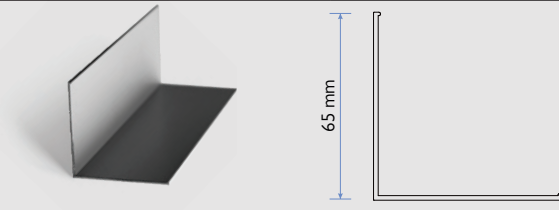
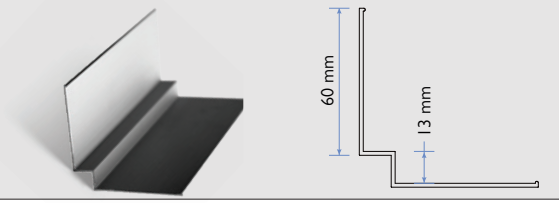
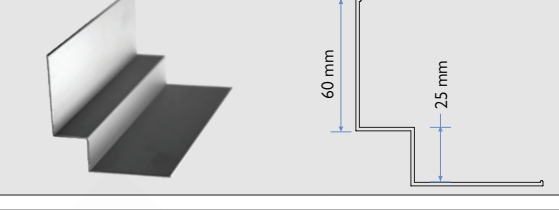
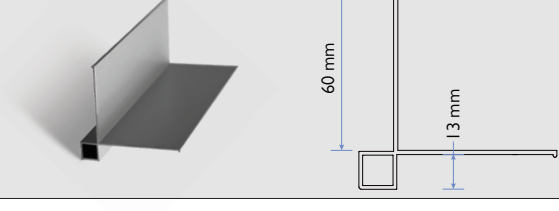
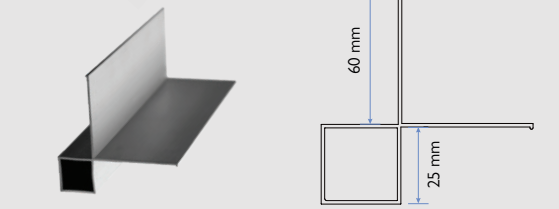
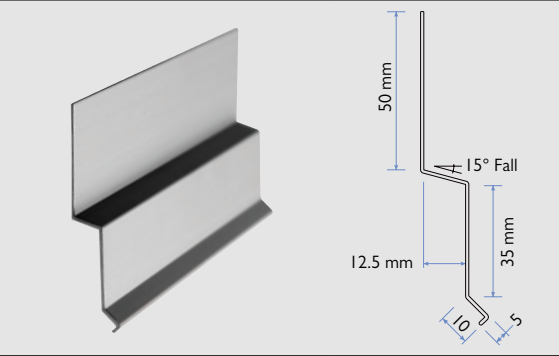
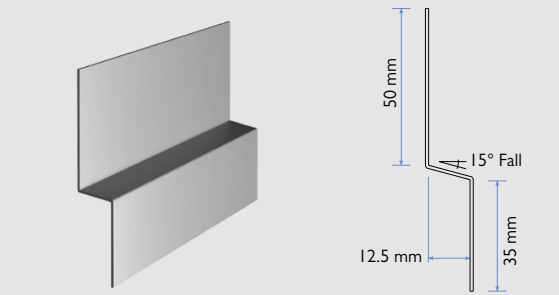
See important notice and warning on page 3.

## I.3 BUILDING MATERIALS FOR USE WITH SHADOWCLAD® (EXTERIOR CLADDING)

### Building Materials Supplied by Other Manufacturers

- Fasteners (i.e. nails or screws) in accordance with Table 10: Fastener Lengths for Shadowclad®.
- Building underlay in accordance with AS/NZS 4200.2 'Pliable Building Membranes and Underlays - Installation' and the manufacturers specifications.
- Window/door head flashings supplied by window joinery company.
- Paint in accordance with paint manufacturers recommendations (refer to 5.3 Coating Selection for more details).

## I.4 PRESERVATIVE TREATMENT

The standard treatment for Shadowclad panels is H3 LOSP (Azole) for use as exterior cladding. H3 LOSP treated Shadowclad is treated in accordance with AS/NZS 1604.3.

**Shadowclad® is envelope preservative treated. Where sheets are cut, cuts must be coated with a brush on timber preservative in accordance with the relevant manufacturer's instructions. Protim® Solignum® XJ Clear Timber Protective (XJ Clear), Arch Lonza Tanalised® Enseal Clear or Tanalised® Ecoseal, is recommended. Failure to properly apply preservative to cut edges will negatively affect the durability of cut panels.**

LOSP treatment does not discolour the panel surface and does not use water in the treatment process allowing panels to remain at uniform dimensions.

When coating H3 LOSP treated plywood some residual solvent may be present on the sheet surface from the treatment process. Sheets feeling greasy to touch should be placed in a well ventilated area and allowed to flash off to ensure proper adhesion of paints and stains to the sheet surface.

Mechanical fasteners are required to fix Shadowclad to framing. Do not glue Shadowclad to frames.

**Table 5: Preservative Treatment**

H3 LOSP (Azole)	
<b>Preservative Carrier</b>	Light organic oil (white spirits)
<b>Colour</b>	Natural
<b>Fungicide</b>	Propiconazole and Tebuconazole
<b>Insecticide</b>	Permethrin
<b>Other Chemicals</b>	Butyl Oxitol (co-solvent to assist active stability)
<b>Mouldicide</b>	IPBC
<b>Notes</b>	Solvent does not affect dimensions. Solvent smell disappears when exposed to air flow
<b>Applications</b>	Exterior (service performance subject to detailing and coatings used)

## I.5 SUSTAINABILITY

Shadowclad is manufactured from radiata pine. It is grown on tree farms which are tended and harvested to provide wood for plywood manufacture. The crop is managed on a sustainable basis to yield millable trees.

New Zealand plantations are managed in compliance with the New Zealand Forest Accord.

Shadowclad is manufactured in New Zealand at the CHH Plywood Tokoroa mill.

Shadowclad is Forest Stewardship Council® (FSC®) (SCS-COC-001316) certified.



## 1.6 PRODUCT IDENTIFICATION

In accordance with AS/NZS 2269, every sheet of Shadowclad® plywood has the following information marked on the back:

- Brand name: e.g. SHADOWCLAD.
- Intended application: e.g. STRUCTURAL.
- Glue bond: e.g. A BOND.
- Formaldehyde emission class: e.g. E0.
- Australasian Standard: e.g. AS/NZS 2269:2012.
- Treatment Standard (if applicable) e.g. AS/NZS 1604.3:2012.
- Date and time of manufacture: e.g. 01/12/15 12:34:56.
- The Engineered Wood Products Association of Australasia (EWPPAA) brand and mill number: e.g. 911 (Tokoroa mill).

### Treated Example:

SHADOWCLAD STRUCTURAL A BOND  
E0 AS/NZS 2269.0:2012  
AS/NZS 1604.3:2012 400 64 H3 E LOSP  
RETREAT CUTS PAT 01/12/15 12:23:45



## 2.0 DESIGN CONSIDERATIONS

### 2.1 DESIGN RESPONSIBILITY

Design responsibility lies with the building owner and the professionals that they engage. The specifier for the project must ensure that the details in the specification for their individual projects are appropriate for the intended application. The specifier must also ensure that additional detailing is provided for specific design or any areas that fall outside the scope and specifications of this literature. It is the specifier's responsibility to ensure that non-CHH Plywood products are fit for purpose, and compatible with Shadowclad products.

Good detailing which avoids moisture or dust accumulation on the sheet surface can help increase durability and aesthetics. Roof overhangs contribute to performance as they offer shade and will protect walls from rain and dust. Trims should be bevelled to shed moisture and flashings should be detailed with gaps that do not trap water at the panel edges.

### 2.2 LITERATURE SCOPE

The information and details within this guide are for direct fix construction only, and may not be suitable for construction of buildings in bush fire prone areas. The Shadowclad Specification and Installation Guide for Cavity Wall Construction can be downloaded from [www.shadowclad.com.au](http://www.shadowclad.com.au).

Shadowclad as a direct fix cladding can be used for those structures which fall within the scope of Part 3.5.3 Wall Cladding of the NCC 2016, Building Code of Australia - Volume Two.

Shadowclad is recommended as a:

- Direct fix cladding where the Shadowclad cladding is fixed directly to the timber frame through the wall underlay. This method is only permitted in low risk buildings.
- Shadowclad as a direct fix cladding is not permitted where a risk score >6 in accordance with Table V2.2.1a Risk Factors of the NCC 2016, Building Code of Australia, Volume Two is established.
- Shadowclad as a direct fix cladding cannot be used in design wind speeds exceeding N3.
- Windows to comply with the requirements of AS 2047.

### 2.3 CODE COMPLIANCE

Shadowclad is manufactured to the requirements of AS/NZS 2269:2012 Plywood: Structural Specifications as per section 3.5.3.4 (C) (i) of the NCC 2016, Building Code of Australia - Volume Two and treated to H3 level via AS/NZS 1604.3 Specification of Preservative Treatment: Plywood. Further to this, Shadowclad for direct fix construction details have been appraised by BRANZ as a direct fix cladding based on installation details included in this literature (for use in New Zealand conditions).

Recommendations made by CHH Plywood are based on good building practice and are not a complete statement of all relevant data. As the design and installation of Shadowclad is influenced by and relies on factors outside the control of CHH Plywood, CHH Plywood assumes no responsibility for works/systems used in connection with the installation of Shadowclad and it's suitability to satisfy relevant Building Codes and Regulations, Standards and Council/Authority/ Regulator requirements.

**See important notice and warning on page 3.**

## 2.4 SITE & FOUNDATIONS

Foundation design must comply with AS 2870 "Residential Slabs and Footings - Construction" and the NCC 2016, Building Code of Australia – Volume Two. The grade of adjacent finished ground

must slope away from the building to avoid the possibility of water accumulating.

## 2.5 GROUND CLEARANCES

The bottom edge of the Shadowclad® sheet must be a minimum of 50mm above decks and verandahs, 100mm above paved ground and a minimum of 175mm above unprotected ground.

Shadowclad must overhang the bottom plate on a concrete slab by a minimum of 50mm. The maximum distance from the bottom of the sheet to the fixing shall not exceed 75mm.

## 2.6 MOISTURE MANAGEMENT

It is the responsibility of the specifier to identify moisture related risks associated with any particular building design and site exposure.

Wall construction design must effectively manage moisture, accounting for both the interior and exterior environments of the building. This is particularly important in buildings that have a higher risk of wind driven rain penetration or that are artificially heated or cooled.

Where a deck is attached to the building and the Shadowclad extends below the deck to cover the framing, keep decking clear of the Shadowclad surface and detail to avoid moisture entrapment.

All wall openings, penetrations, junctions, connections, window sills, heads and jambs must incorporate Shadowclad flashings for waterproofing. Materials, components and the installation used to manage moisture in framed wall construction must, at a minimum, comply with the requirements of relevant Sections and Clauses of the NCC 2016, Building Code of Australia - Volume Two.

## 2.7 WIND LOADING

Shadowclad as a direct fix cladding is suitable for use in all wind classification up to and including N3 and C1 as defined by AS 1684. Shadowclad on a drained and vented cavity system (Cavity

Wall Construction) is suitable for buildings in wind classifications N4 or C2 and specific design wind pressures up to design differential ultimate limit state (ULS) of 2.5kPa.

## 2.8 DURABILITY

The durability level applicable to Shadowclad is dependent upon the application and coating applied. Detailing, treatment and installation methods need careful consideration to satisfy the requirements of the Australian Building Codes Board (ABCB) guidelines document, Durability in Building.

**CHH Plywood does not recommend Shadowclad is left uncoated when used as an exterior cladding.**

The ABCB guideline document, Durability in Building, requires cladding to achieve a minimum structural durability level of 15 years.

Shadowclad coated with stains or paints (regardless of colour choice) will meet this requirement. If using dark colours (colours

with an LRV of less than 50%) homeowners should expect an increased level of coating maintenance over the life of the cladding than would normally be expected where lighter colours are used.

**Using dark colours with an LRV of less than 50% and failure to adequately maintain the surface coating of the cladding increases the risk of aesthetic related issues such as face checking.**

### **Additional Notes:**

For further advice on coatings refer to section 5.0 Coating and Application – Exterior Cladding.

## 2.9 TEXTURED VS. SMOOTH FINISHED PLYWOOD AS EXTERIOR CLADDING

Structurally, some smooth faced plywood products may be suitable as a cladding however in CHH Plywood opinion smooth faced plywood does not retain a high level of appearance when directly exposed to weathering.

Where a high level of appearance is desired (such as exterior cladding) CHH Plywood recommends the use of Shadowclad rather than smooth faced plywood.

Shadowclad® features a textured (bandsawn) face which reduces the visibility of natural surface checking which can occur in any wood based product which has been exposed to weather for a prolonged period.

Face checks are not considered a manufacturing fault as they are part of a natural process and are merely an indication that it is time to re-apply the surface coating on the product.



## 2.10 HEALTH & SAFETY

---

Shadowclad should be installed and used as per the Safety Data Sheet (SDS) which can be downloaded from [www.shadowclad.com.au](http://www.shadowclad.com.au).

Always wear safety glasses or non-fogging goggles when cutting Shadowclad panels and flashings.

If wood dust exposures are not controlled when machining (sawing, routing, planing, drilling etc.) a class P1 or P2 replaceable filter or disposable face piece respirator should be worn.

Wear comfortable work gloves to avoid skin irritation and the risk of splinters. Wash hands with mild soap and water after handling panels.

## 2.11 STORAGE & HANDLING

---

### Shadowclad® Panels:

- Keep Shadowclad panels dry.
- Store under cover.
- Handle and stack with care to avoid damage.
- Stack flat; clear of ground, on at least three evenly spaced bearers.
- Store in well-ventilated areas away from sources of heat, flames or sparks.

### Shadowclad Flashings:

- Keep dry. Should a shipment of Shadowclad flashings arrive in a wet condition, they should be immediately dried before storing.
- When storing flashings avoid contact with other metals which may cause scratches or marks. The use of shelving or racks faced with dry wood is recommended.
- Keep away from caustics, nitrates and acids.

## 3.0 INSTALLATION - INTERIOR LININGS

The use of treated Shadowclad is not recommended for internal wall and ceiling linings. CHH Plywood has developed Shadowply®, an interior range of untreated panels for internal applications where termite treatment is not required.

For detailed installation advice for plywood used as an internal lining refer to the Shadowply Information Guide, which is available to be downloaded from [www.shadowply.com.au](http://www.shadowply.com.au)

**See important notice and warning on page 3.**

## 4.0 INSTALLATION – EXTERIOR CLADDING

### 4.1 FRAMING – CONSTRUCTION

Use kiln dried framing in accordance with timber framing manufacturer's specifications. Timber frame sizes and set out must comply with AS 1684 (or specifically designed to AS 1720.1) and with stud and nog centres and timber width required by this specification.

Allow a 6mm capillary gap behind panels where they overlap the edge of the concrete floor, brick veneer or lower storey cladding.

All Shadowclad® sheet edges must be fully supported by framing.

- Studs must not exceed 600mm centres.
- Nogs must be provided at a maximum of 800mm centres.
- Framing must be kept as dry as possible at all times.
- Single spans of Shadowclad must not exceed 600mm (e.g. Below windows or balustrades).

Where used for bracing framing should have a minimum joint strength group of J4 or JD4.

### 4.2 PREPARATION – BUILDING UNDERLAY

The use of building underlay compliant with AS/NZS 4200.2 "Pliable Building Membranes and Underlays - Installation" and the manufacturers recommendations, or an alternative solution must be provided over framing prior to cladding installation.

Barriers to air flow are required regardless of direct or cavity construction.

### 4.3 PREPARATION - DIRECT FIX CONSTRUCTION

The NCC 2016, Building Code of Australia - Volume Two allows direct fix construction. Please use the risk matrix in Table V2.2.1a of the NCC 2016, Building Code of Australia - Volume Two

to determine the risk score of your building envelope. For risk scores > 6 CHH Plywood recommends the use of cavity wall construction.

#### SC001: Typical Framing Setout Studs at 600 centres

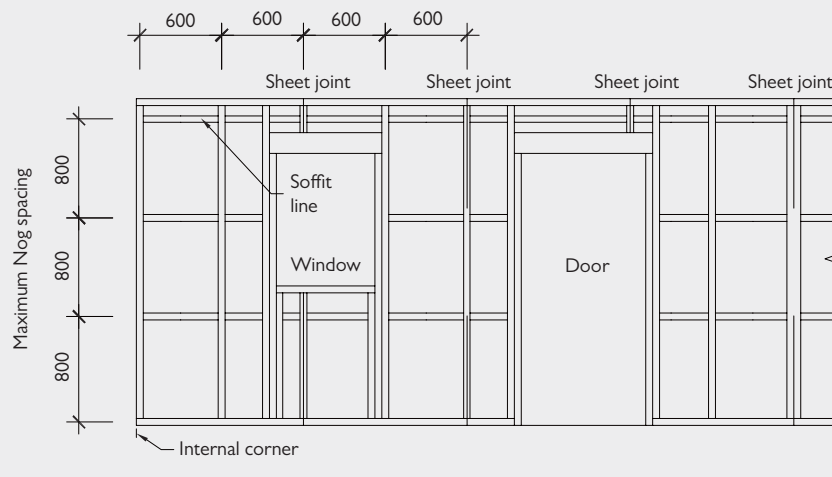

Note:

1. Single spans of Shadowclad® must not exceed 600 mm (e.g. below windows or on balustrades)

## SC001A: Typical Framing Setout Studs at 400 centres

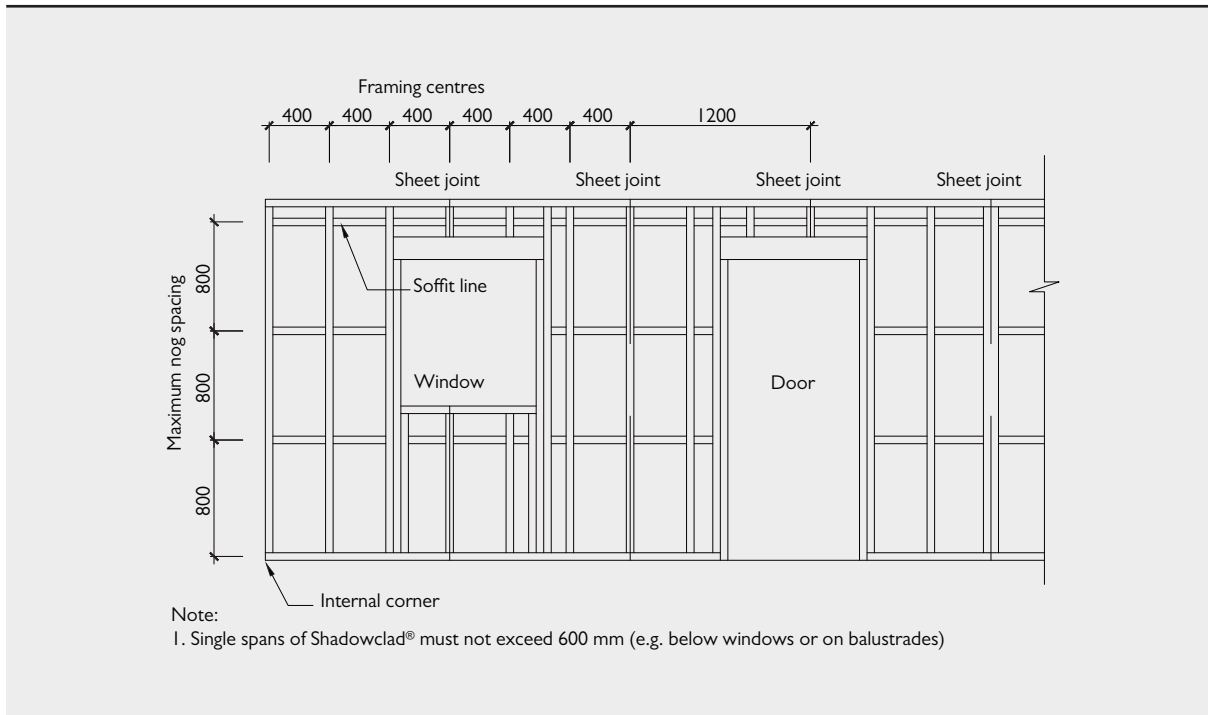

## 4.4 SHEET LAYOUT

A sheet layout should form part of architectural drawings and be used from the basis of stud/framing layout.

- Sheet edges must be supported by the framing.
- Sheets are designed to be vertically fixed. **Do not fix sheets horizontally.**
- When laying up on to framing, start at framing corners and work across the wall.
- All treated Shadowclad® panels are envelope preservative treated. Where sheets are cut, edges **must** be coated with a brush on timber preservative.
- Cut edges must be placed at the top of the sheet to avoid rain drips soaking in to cut end grains.
- Priming of bottom edges and the back (rear) of the sheets to a height of 150mm is required.
  - Shadowclad Ultra sheets are coated on the rear to a height of 150mm to meet this requirement.

## 4.5 FIXINGS – FASTENER DURABILITY

**Table 6: Fastener Durability for Shadowclad® Cladding**

Finish	Treatment	Exposure Zone	Material Required
Shadowclad Natural/Ultra	H3 LOSP	Normal	Minimum hot dipped galvanised or better
		Sea Spray*	Stainless Steel

\* As defined in Section 1.2, Sea Spray Exposure

See important notice and warning on page 3.

## 4.6 FIXINGS – FASTENER SIZE & LAYOUT

**Table 7: Fastener Lengths for Shadowclad® Cladding**

Fastener Length and size (Direct Fix)	
Nails in Timber	50 x 2.8mm
Screws in Timber	8g x 40mm

Shadowclad **must be** nailed or screwed to timber as per below:

- Use flat head (full round head) nails with timber framing.
- Standard fixing pattern: fasten sheet edges at 150mm centres and within the panel on all supports at 300mm centres.
- Fasten no closer than 7mm to sheet edges except on edge with top lap (weather groove lap), **do not nail through top lap.**
- Fasten ship lap joints independently to ensure natural sheet expansion is not restricted.
- Drive nails and screws flush.
- Do not nail through the grooves in Shadowclad Groove panels.

### Power Driven Fastening

- Best practice is to hand drive nails as better control of nail depth is achieved.
- Power driven nailers may be used to fire power driven nails.
- Do not overdrive nails into the sheet.

### Fixing at Vertical Sheet Join

Shadowclad Sheets must be fastened off independently to each other. SC005A and SC007A show specific fastener locations to accommodate the Ship lap joint. For Shadowclad Texture and Shadowclad Groove respectively fasten underlap 13mm from sheet edge, with overlap fasten 23mm from sheet edge as detailed.

## 4.7 INSTALLATION TOOLS FOR SHADOWCLAD®

Correct installation and maintenance of Shadowclad is necessary to ensure that compliance with the NCC 2016 Building Code of Australia, Volume Two, durability, structural integrity and weathertightness are maintained. CHH Plywood is proud to introduce two installation tools to compliment the Shadowclad Specification and Installation Guides. These products are an extension of the Specification and Installation Guides and are available by contacting CHH Plywood directly via [www.shadowclad.com.au](http://www.shadowclad.com.au) or by calling 1800 338 463.

### Shadowclad® sTe APP

The Shadowclad sTe APP is a tool for all building practitioners to aid in the installation of Shadowclad in accordance with the CHH Plywood Specification and Installation Guides. The APP includes a context sensitive Key Design Points and Installation Checklist, access to all current literature, installation details, maintenance and other key installation requirements.

### Shadowclad Stick

The Shadowclad Stick is an installation tool for Shadowclad. This tool removes the need for builders to develop their own 'jigs' to aid in ensuring that critical clearances, nail spacings, etc. are applied during the installation of Shadowclad sheets.

## 4.8 SHADOWCLAD® KEY INSTALLATION & DESIGN POINTS

The following tasks are provided to installers to point out key installation and design factors when used as an exterior cladding. These do not detract from the requirements to read and understand this literature as a whole.

Task	Tick when checked
<b>Prior to Specification and Installation</b>	
Read the Shadowclad® Specification and Installation Guide in its entirety	<input type="checkbox"/>
<b>Framing Plan</b>	
Framing setout drawings to suit Shadowclad fixing and installation guidelines	<input type="checkbox"/>
<b>Sheet Cuts</b>	
Coat all sheet cuts with a preservative timber treatment such as XJ Clear, or similar	<input type="checkbox"/>
After applying the timber preservative treatment, apply the surface coating (e.g. paint or stain) to cut edges	<input type="checkbox"/>
Place uncut edge to bottom	<input type="checkbox"/>
<b>Fastener Material Type</b>	
Galvanised fasteners or better used (Stainless steel annular groove nails required in sea spray zones)	<input type="checkbox"/>
<b>Sheet Fastener Pattern</b>	
Around sheet edge – maximum 150mm centre spacing	<input type="checkbox"/>
Within sheet body – maximum 300mm centre spacing	<input type="checkbox"/>
<b>Horizontal Sheet Joints</b>	
Minimum 9mm separation gap between sheets above all Horizontal 'Z' flashings	<input type="checkbox"/>
Prime the bottom of the sheet edge and 150mm up the back (rear) of the sheets	<input type="checkbox"/>
50 mm strip of neutral cure silicon sealant at all 'Z' flashing terminations excluding terminations at Shadowclad metal corner flashings	<input type="checkbox"/>
Back flashings or 150mm overlap to all flashing butt joints	<input type="checkbox"/>
<b>Expansion Gaps Between Sheets (Vertical Sheet Joints)</b>	
Texture Profile Sheets - 2mm gap between vertical edges of sheets	<input type="checkbox"/>
Groove Profile Sheets - 9mm gap (i.e. full groove space) between vertical edges of sheets	<input type="checkbox"/>
Note: Expansion gaps required between vertical edges of sheets to accommodate natural expansion and contraction of sheets	
<b>Ground Clearances</b>	
Paved/Sealed Ground - minimum 100mm distance from the ground to sheet bottom	<input type="checkbox"/>
Broken Ground - minimum 175mm distance from the ground to sheet bottom	<input type="checkbox"/>
Apply the surface coating on the sheet edge and 150mm up the rear of the back of the sheet	<input type="checkbox"/>

Refer to the current Shadowclad® Specification and Installation Guide for full installation specifications and suggested details.

See important notice and warning on page 3.

## SC003A: Shadowclad® Fastener Layout

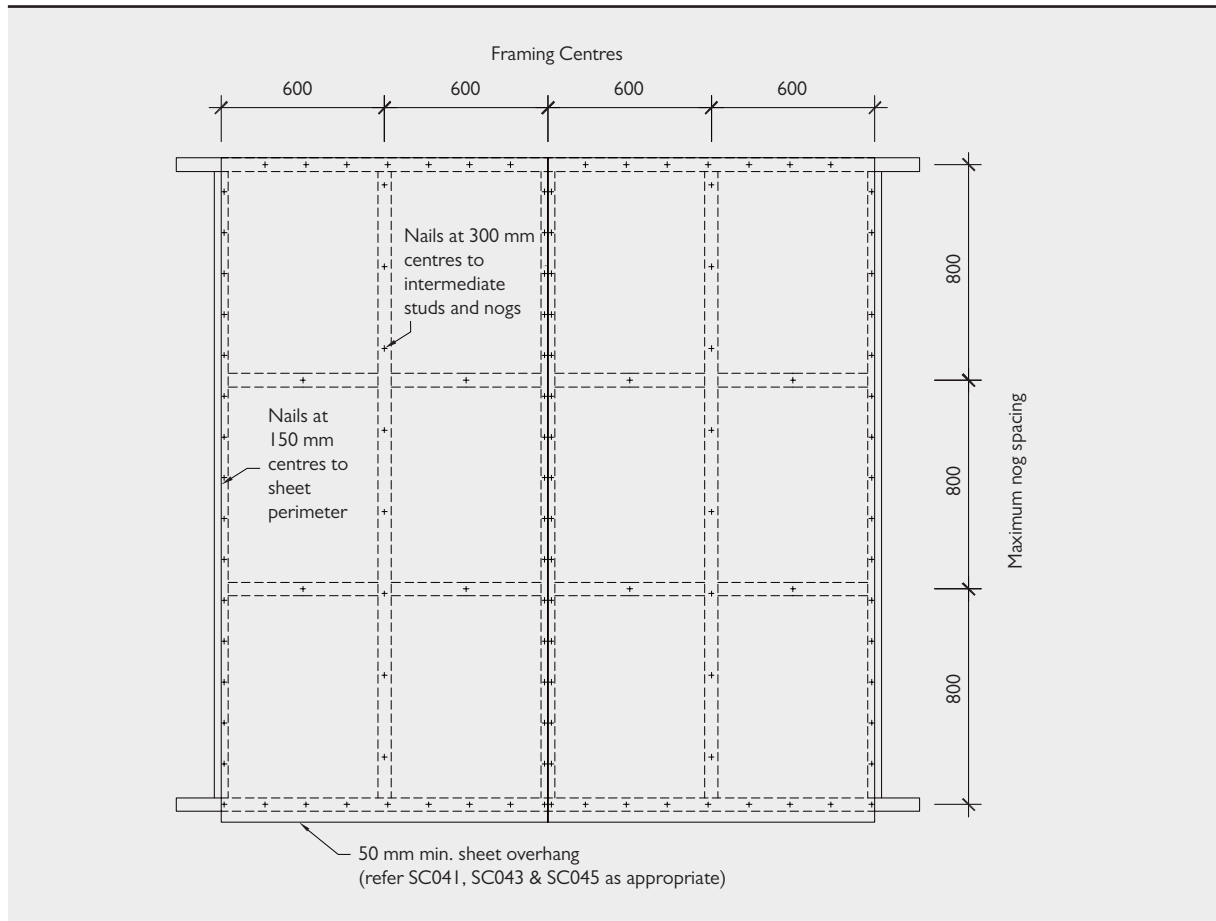

## 4.9 VERTICAL SHEET JOINTS

Shadowclad® sheets have a built-in ship lap joint and weather groove on the long edges of all sheets.

When installing Shadowclad Groove profile sheets, use a 9mm temporary spacer in the groove alongside ship lap joint to establish correct expansion gap.

**Shadowclad® is envelope preservative treated. Where sheets are cut, cut edges must be coated with a brush on timber preservative in accordance with the relevant manufacturer's instructions. XJ Clear, Arch Lonza Tanalised® Enseal Clear or Tanalised® Ecosal is recommended. Failure to properly apply preservative to cut edges will negatively affect the durability of cut panels.**

## SC004: Shadowclad® Texture and Groove Sheet Dimensions

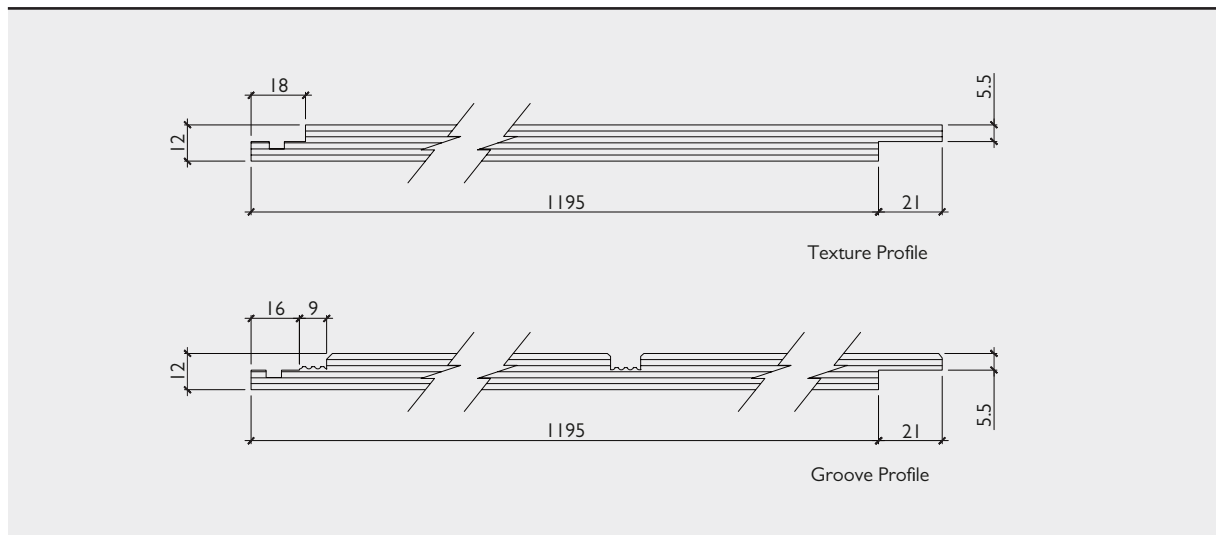





### SC005: Shadowclad® Texture Vertical Joint (Direct Fix)

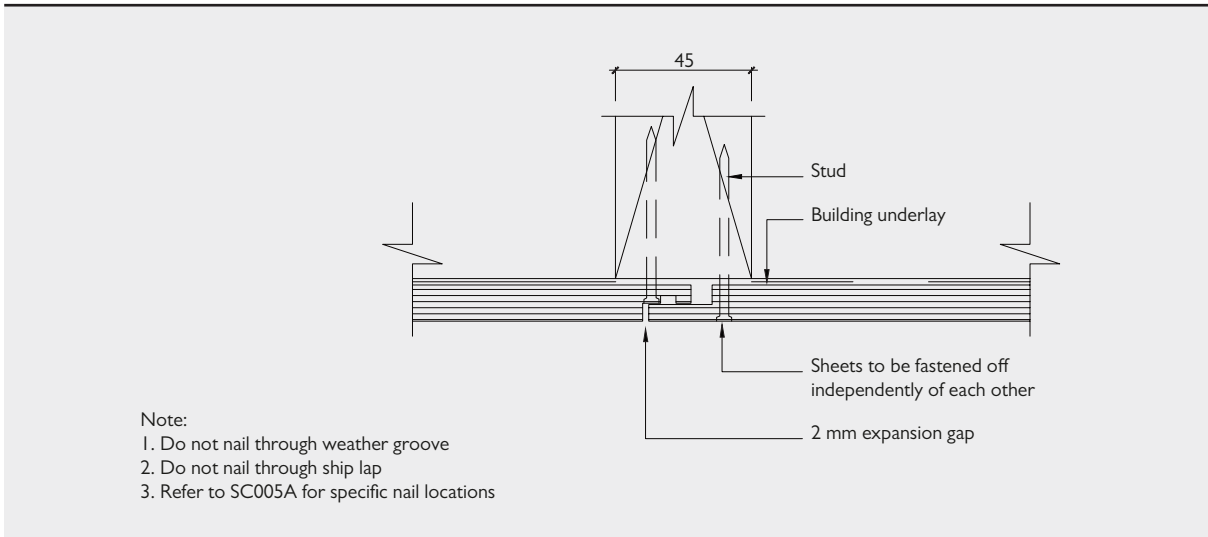

### SC005A: Shadowclad Texture Vertical Joint Fastener Locations (Direct Fix)

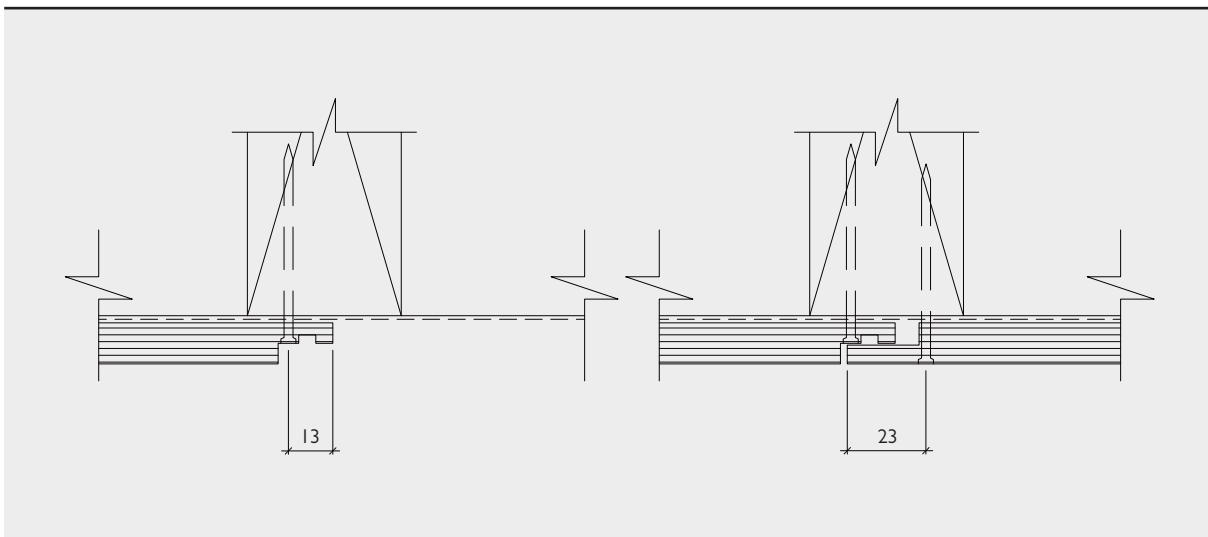

### SC007: Shadowclad® Groove Vertical Joint (Direct Fix)

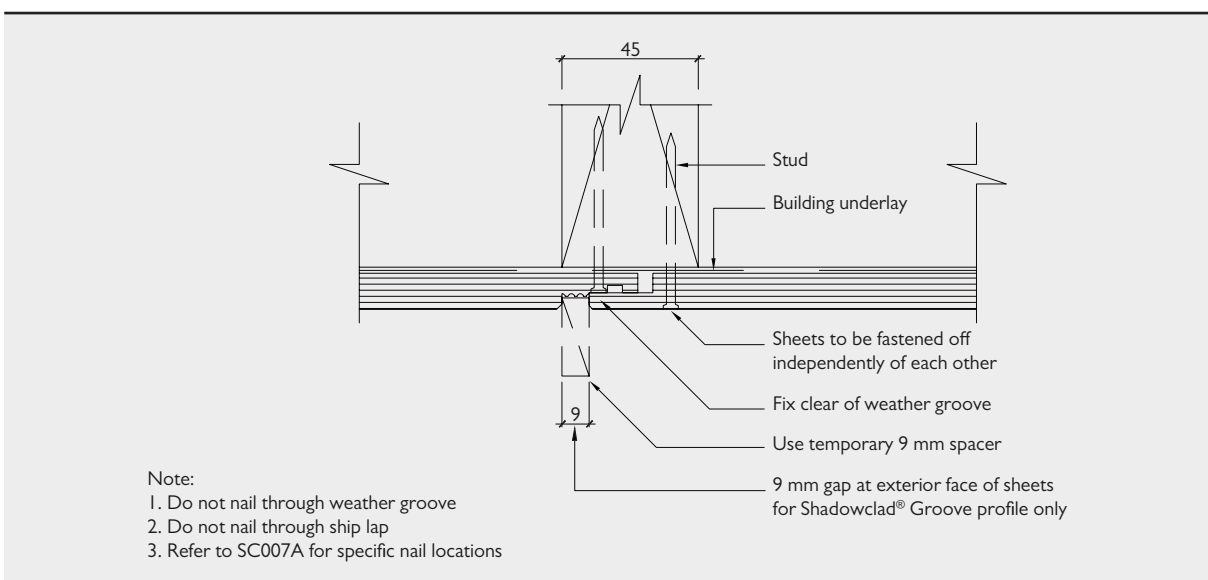

See important notice and warning on page 3.

SC007A: Shadowclad® Groove Vertical Joint Fastener Locations (Direct Fix)

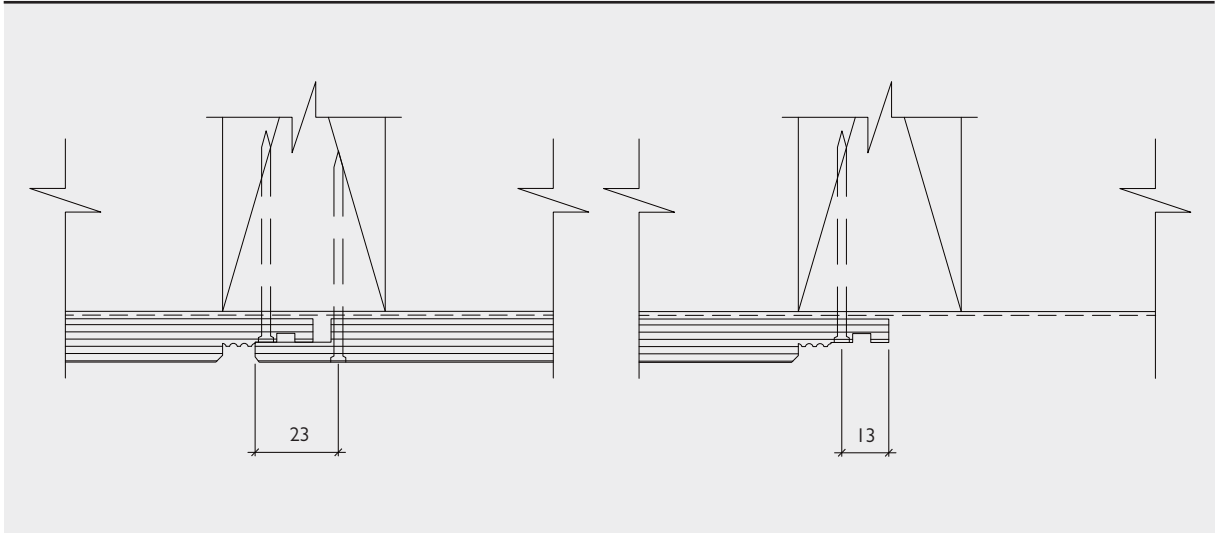

SC009: Shadowclad® Vertical Joint with Optional Cover Batten (Direct Fix)

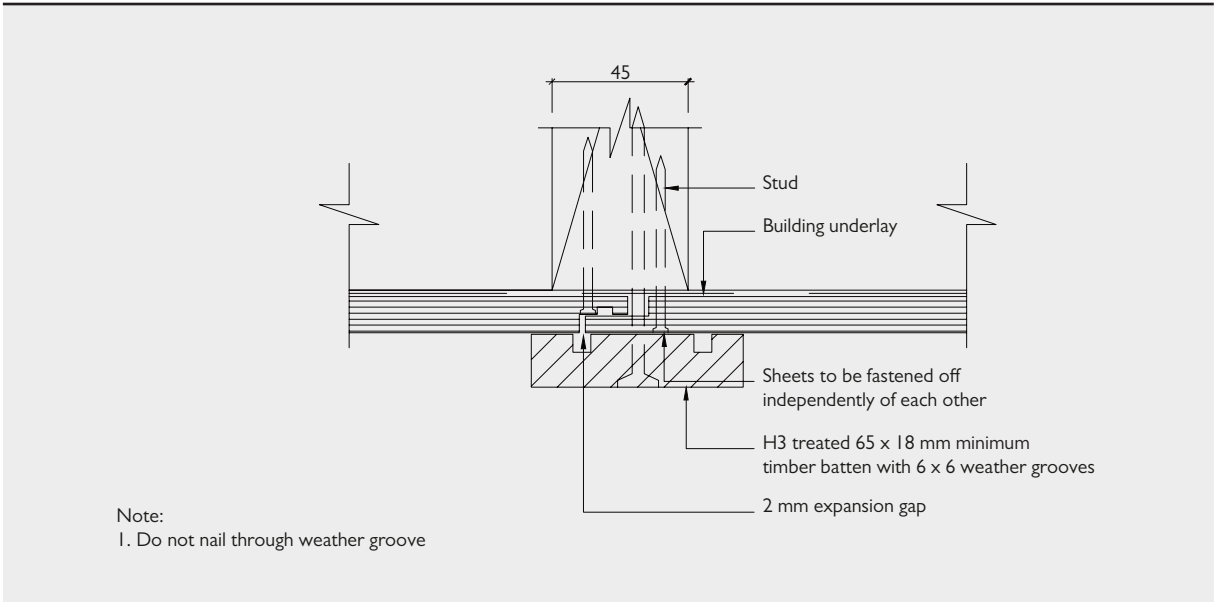

**SC011: Shadowclad® Nogging for Vertical Cover Batten Between Studs (Direct Fix)**

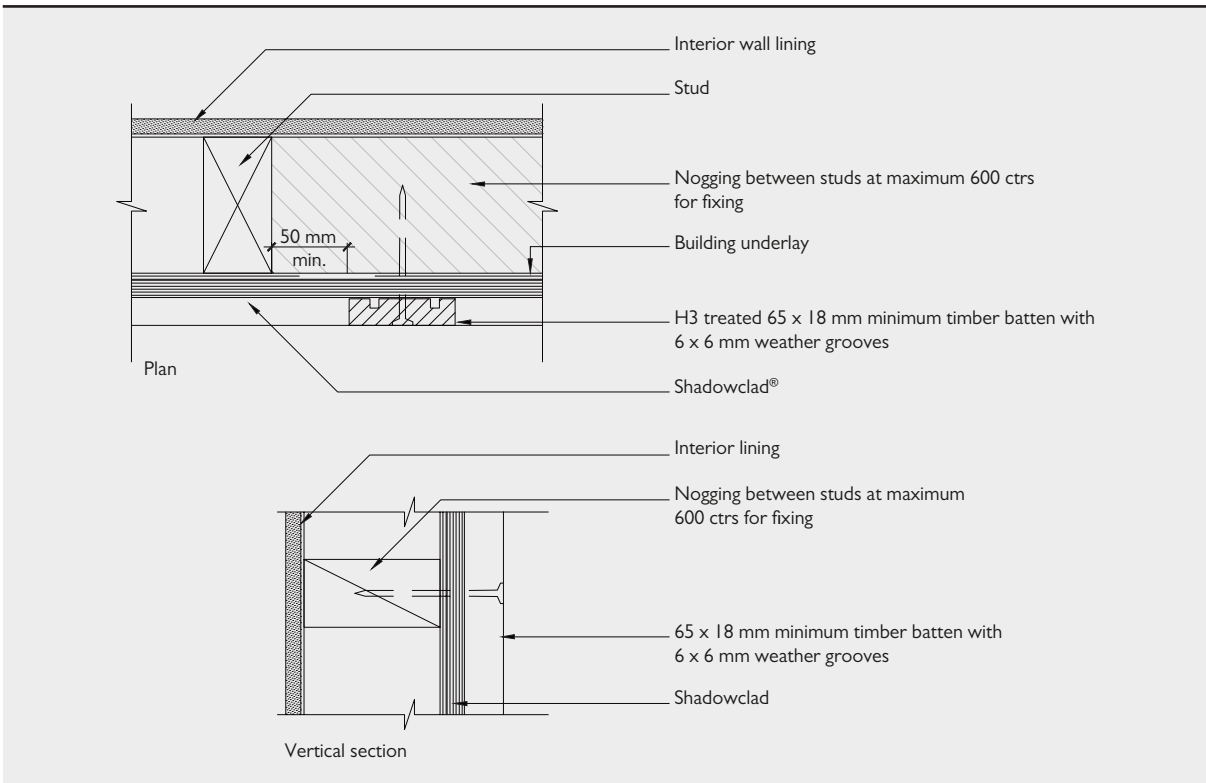

**SC013: Shadowclad® Vertical Joint with Top Hat Flashing (Direct Fix)**

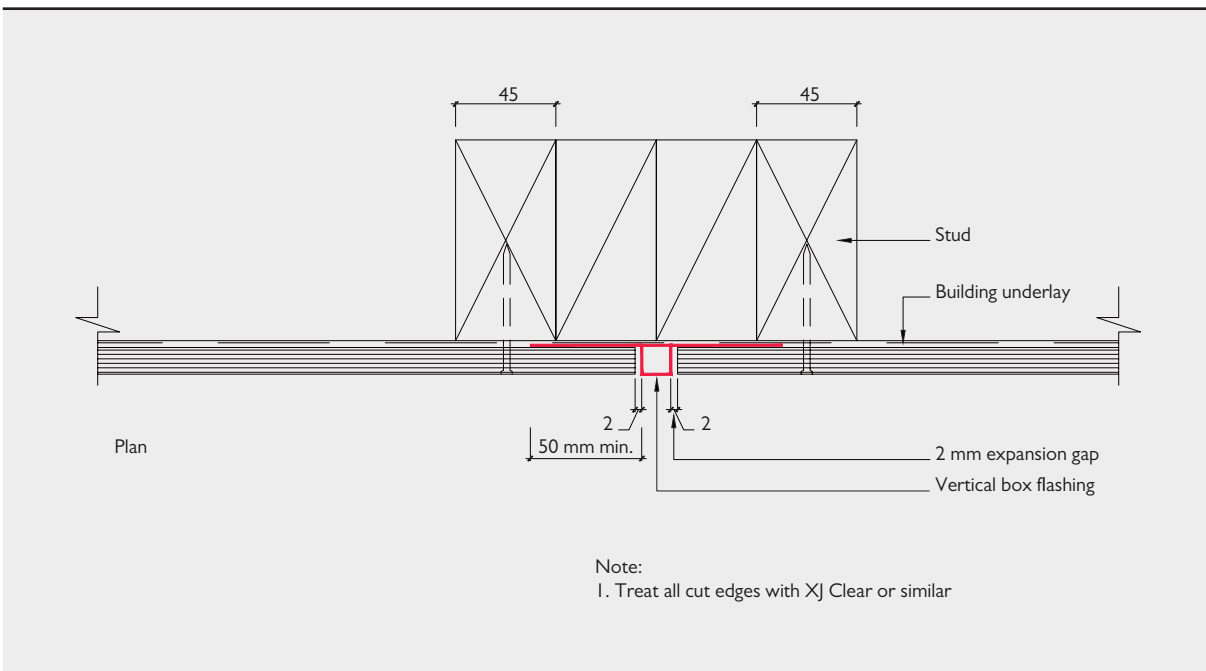

See important notice and warning on page 3.

## 4.10 HORIZONTAL SHEET JOINTS

At floor joist level a horizontal joint must be provided to accommodate the movement resulting from timber joist shrinkage and settlement.

A Shadowclad® Horizontal 'Z' flashing should be used for horizontal sheet joints.

Note: When direct fixing Shadowclad, additional building wrap is used to lap over the 'Z'-flashing upstand. Alternatively, flashing tape should be dressed over the flashing upstand.

If aluminium 'Z' flashings are being used, all butt joints must include proprietary back flashings. Stainless steel flashings should be lapped by a minimum 150 mm at joints.

A 50 mm strip of neutral cure silicon (refer SC0101 General Silicon Sealing of Horizontal 'Z' Flashings detail below) is required at all 'Z' flashing terminations excluding terminations at Shadowclad metal corner flashings.

### SC0101: Shadowclad® General Silicon Sealing of Horizontal 'Z' Flashings

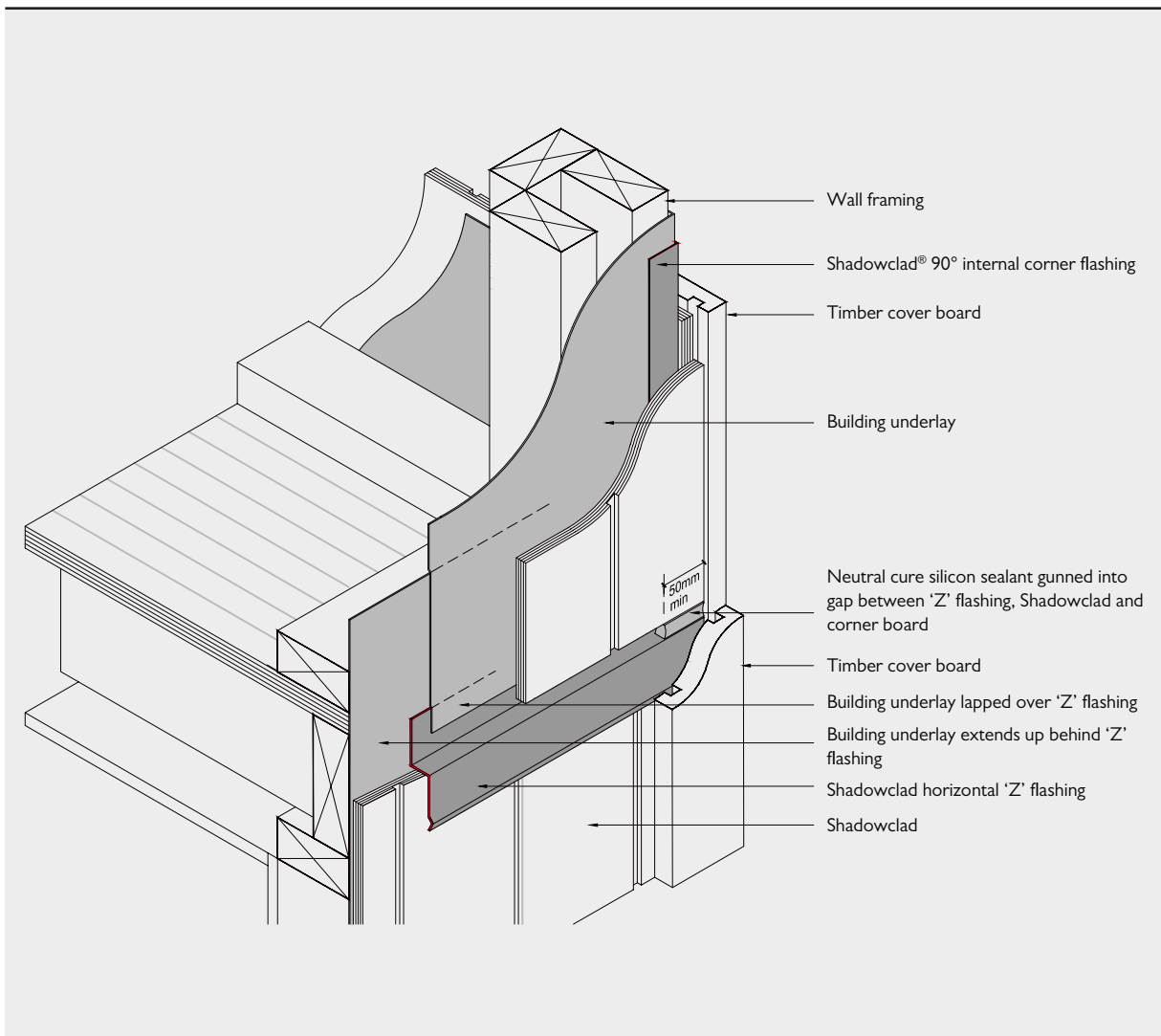

## SC015: Shadowclad® Mid Floor Horizontal Joint (Direct Fix)

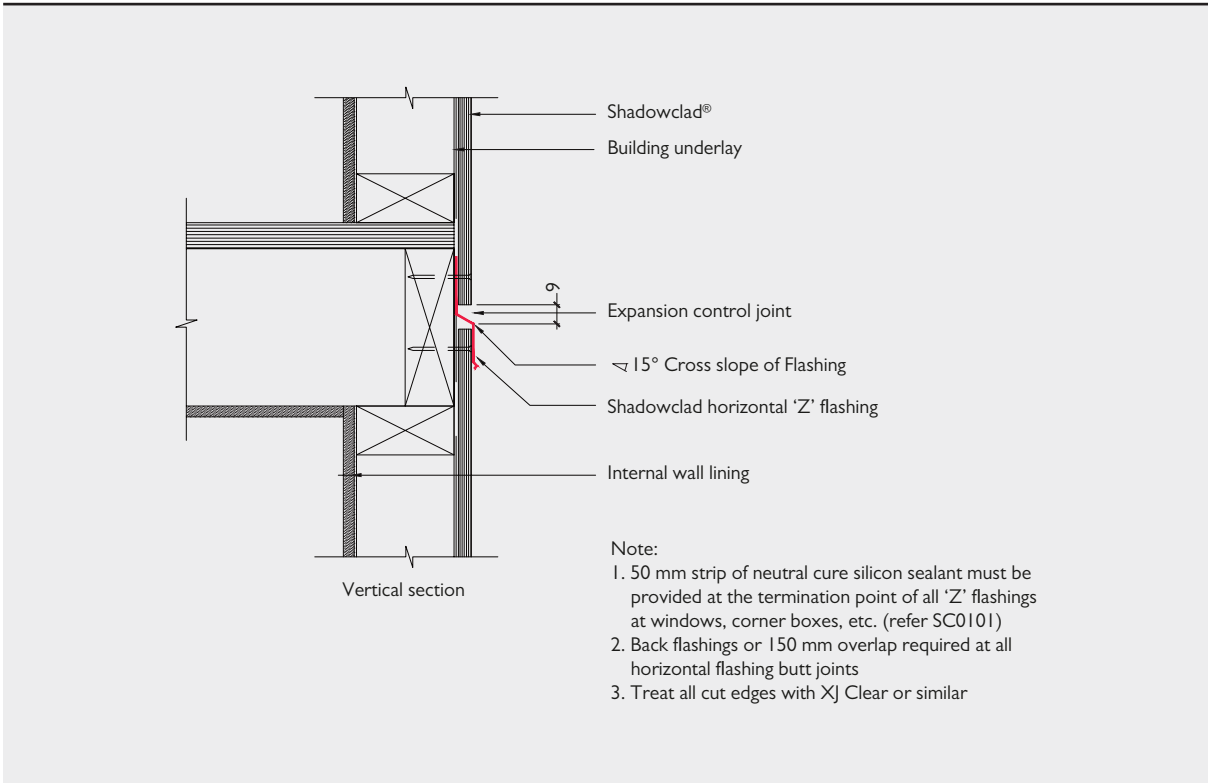

## 4.11 EXTERNAL CORNERS

## SC019: Shadowclad® External Corner with External Box Flashing (Direct Fix)

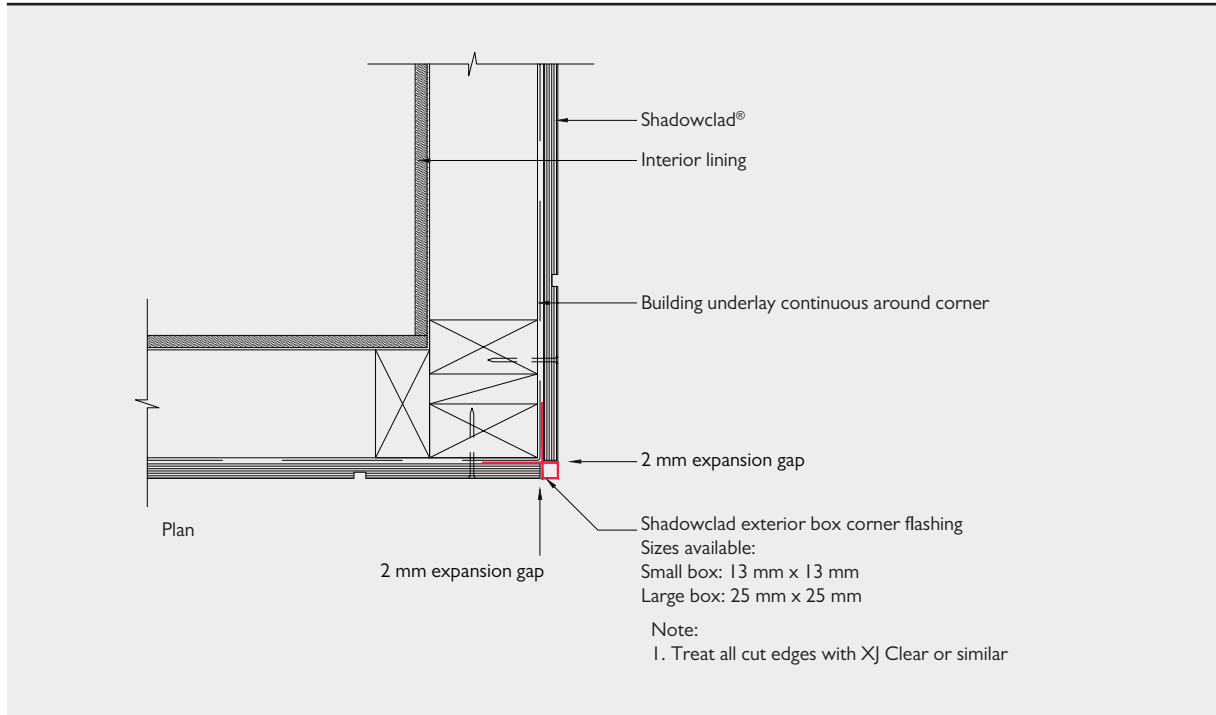

## SC021: Shadowclad® External Corner with Cover Boards (Direct Fix)

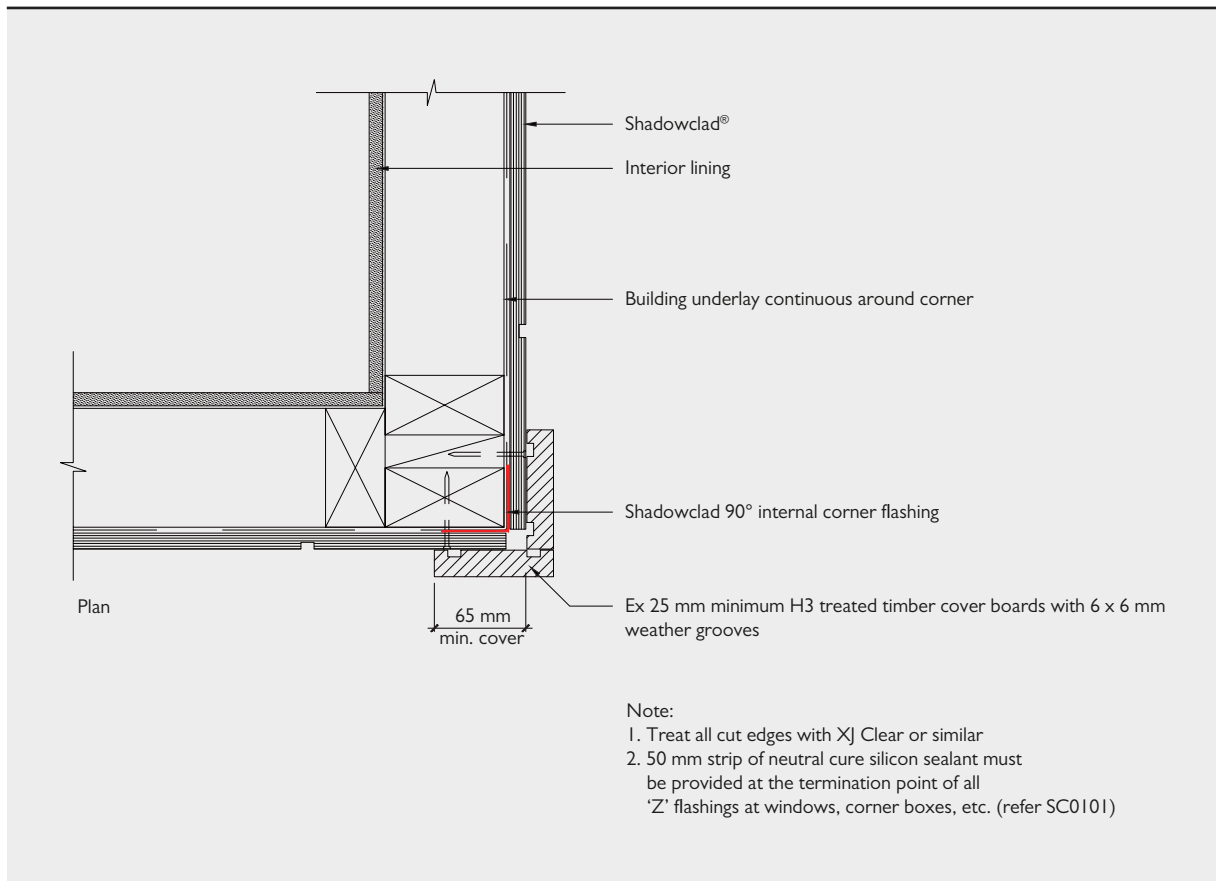



## 4.12 INTERNAL CORNERS

### SC023: Shadowclad® Internal Corner with 90° Flashing (Direct Fix)

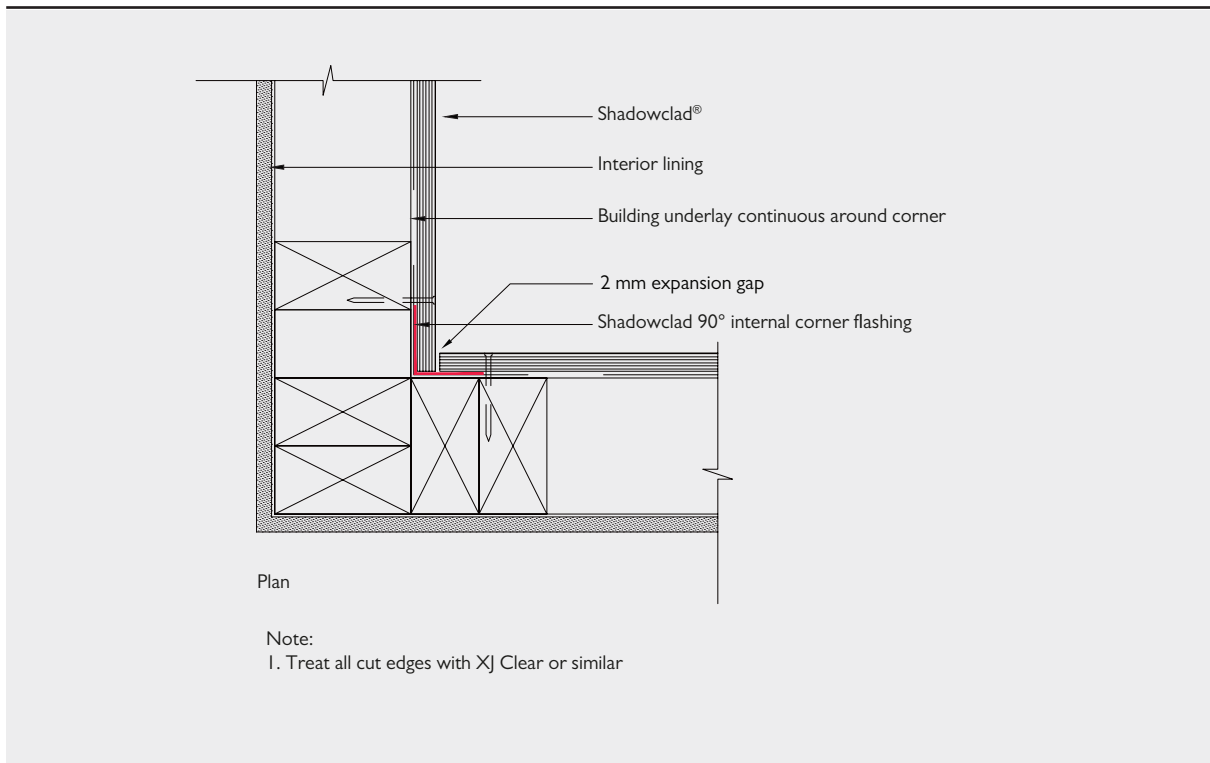

### SC025: Shadowclad® Internal Corner with 'W' Flashing (Direct Fix)

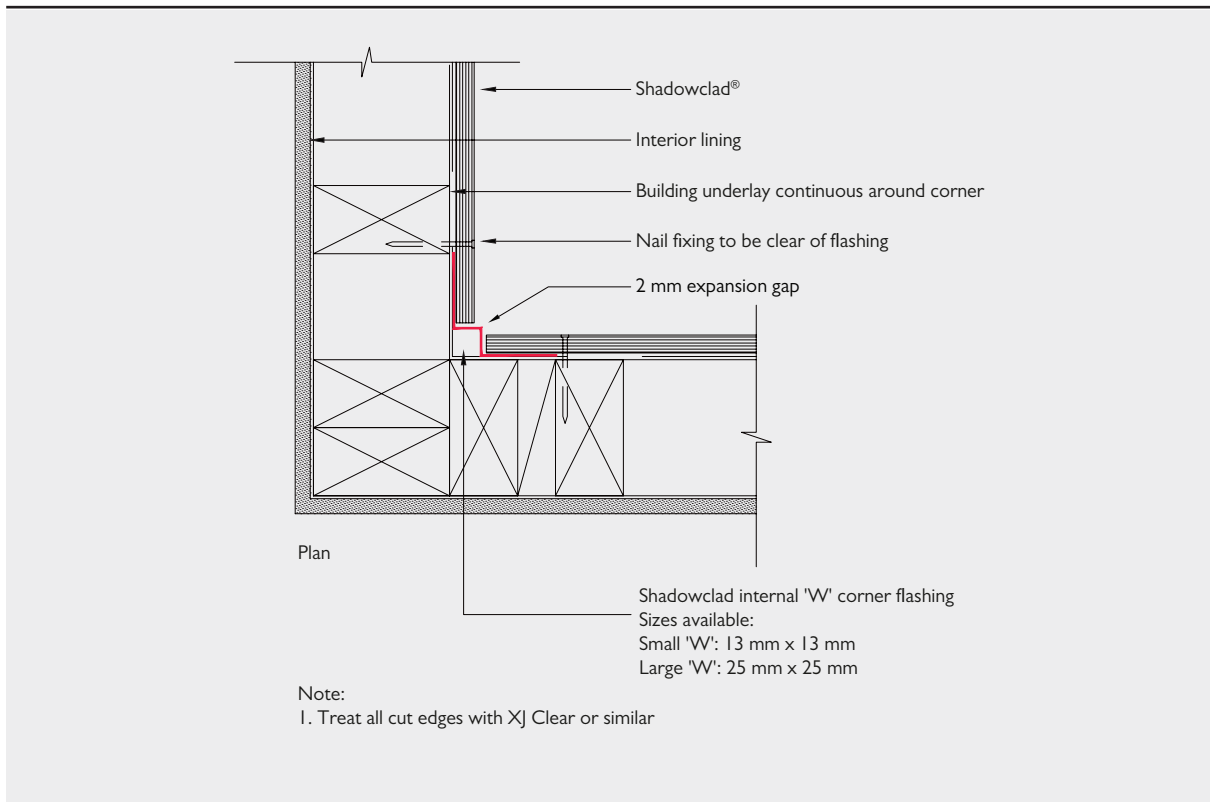

See important notice and warning on page 3.

## 4.13 SHADOWCLAD® FLASHING JUNCTION POINTS

Flashings should have expansion joints where necessary to provide adequate allowance for thermal expansion as set out below.

- Expansion joints to be provided for joined flashings with a combined length exceeding 8 metres
- Even if less than 8 metres in length, where both ends of a flashing are constrained and fixed allowance should be made for expansion.

### Internal & External Flashings

Internal and external angles and 'Z' flashings can be nominally fixed with hot dipped galvanised, or stainless steel (as appropriate) flat head nails and then permanently fixed with the Shadowclad® fasteners penetrating the flashing wings/upstands.

### Horizontal 'Z' Flashings

Horizontal aluminium 'Z' flashings should be butted together with a back flashing to create a weathertight joint (refer SC0103).

Stainless steel flashings should overlap by a minimum of 150 mm at joints to create weathertight joints where horizontal flashings meet (refer SC0105).

### 'Z' Flashings Terminations

A 50 mm strip of neutral cure silicon (refer SC0101 General Silicon Sealing of Horizontal 'Z' Flashings) is required at all 'Z' flashing terminations excluding terminations at Shadowclad metal corner flashings.

### SC0103: Shadowclad® Aluminium Flashing Junctions and Connections (Direct Fix)

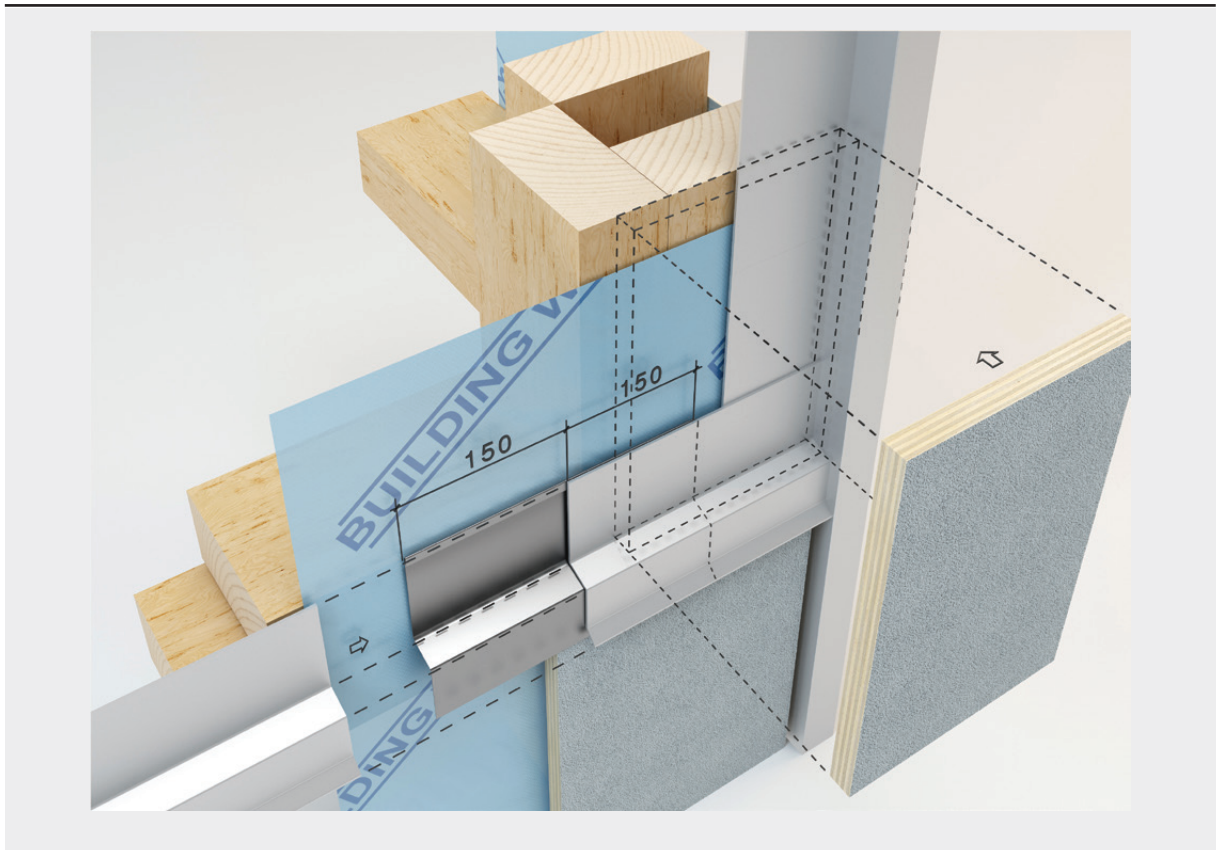



SC0105: Shadowclad® Stainless Steel 'Z' Flashing Joins (Direct Fix)

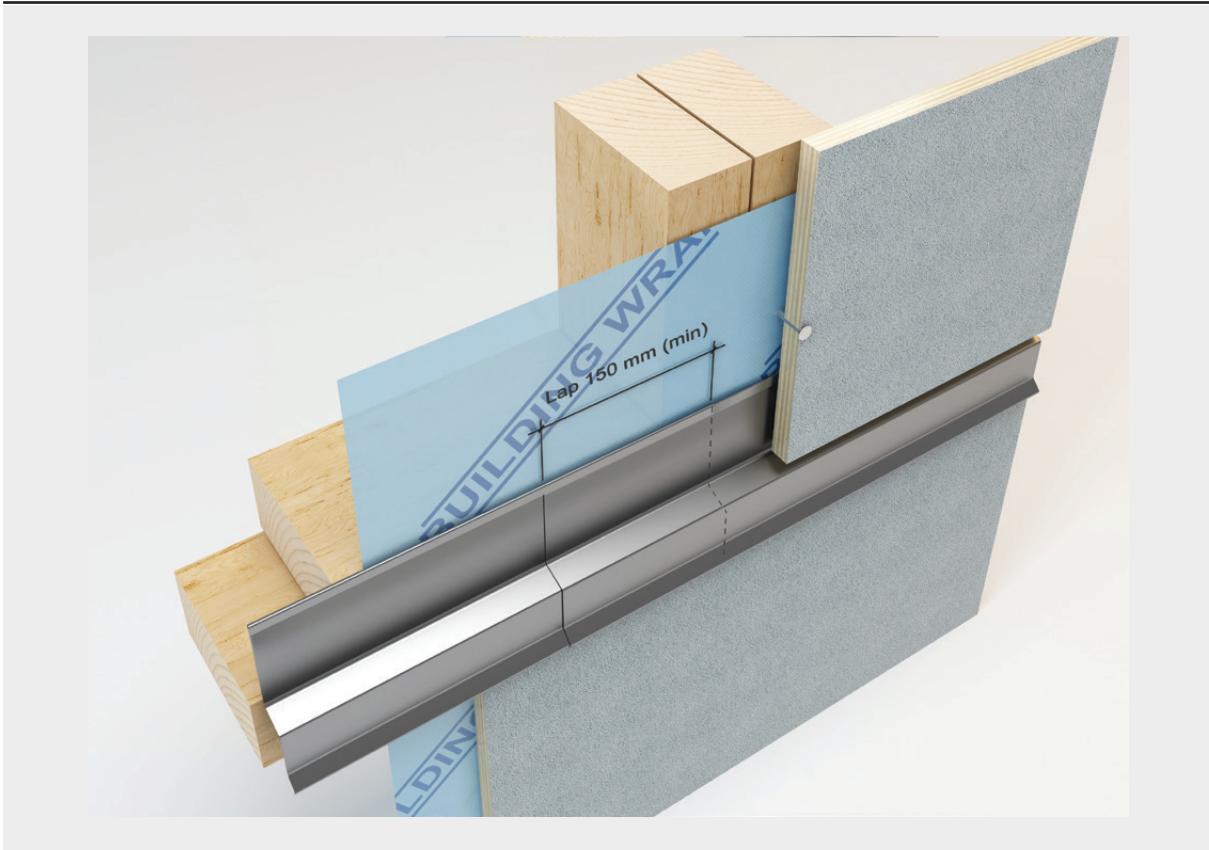

See important notice and warning on page 3.

## 4.14 WINDOW PENETRATIONS

Window joinery flashings (i.e. head and sill flashings) should be sourced from the joinery fabricator to meet the requirements of NCC 2016, Building Code of Australia - Volume Two or an

Alternative Solution such as the Australian Window Association Installation System (AWA).

### SC027: Shadowclad® Window Head Detail (Direct Fix)

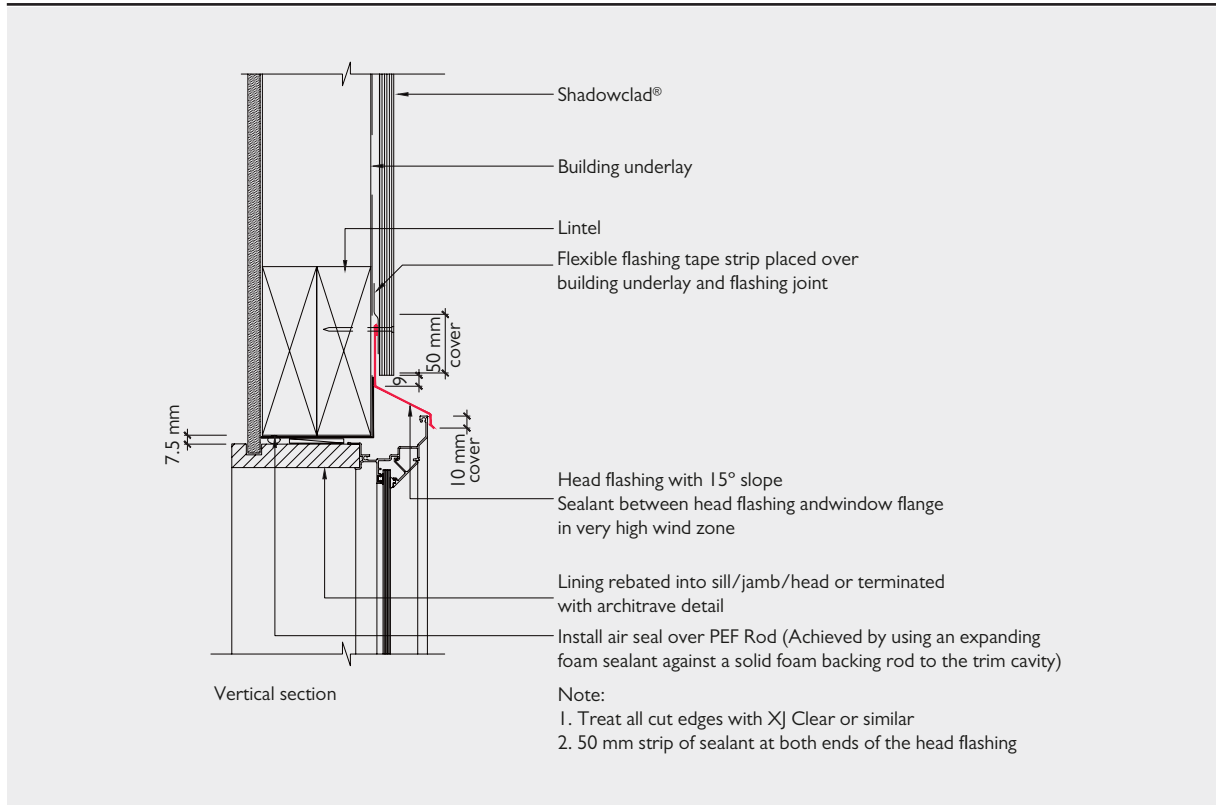

### SC029: Shadowclad® Jamb Detail (Direct Fix)

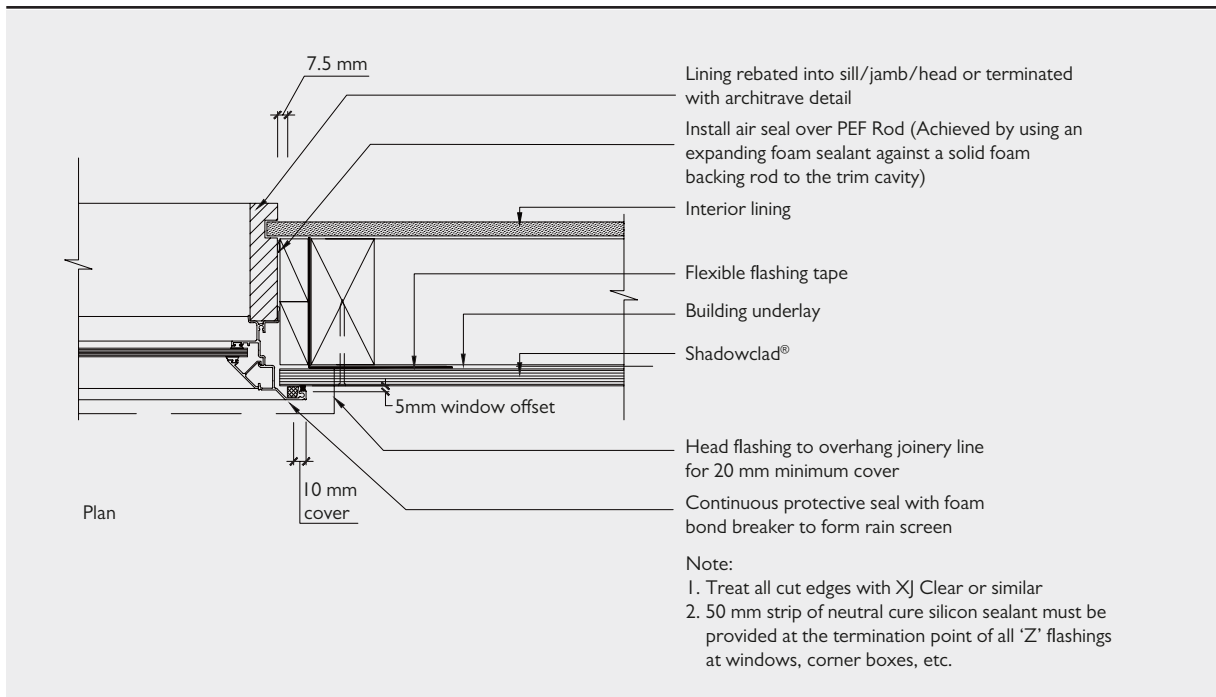

**SC03 I: Shadowclad® Window Sill Detail (Direct Fix)**

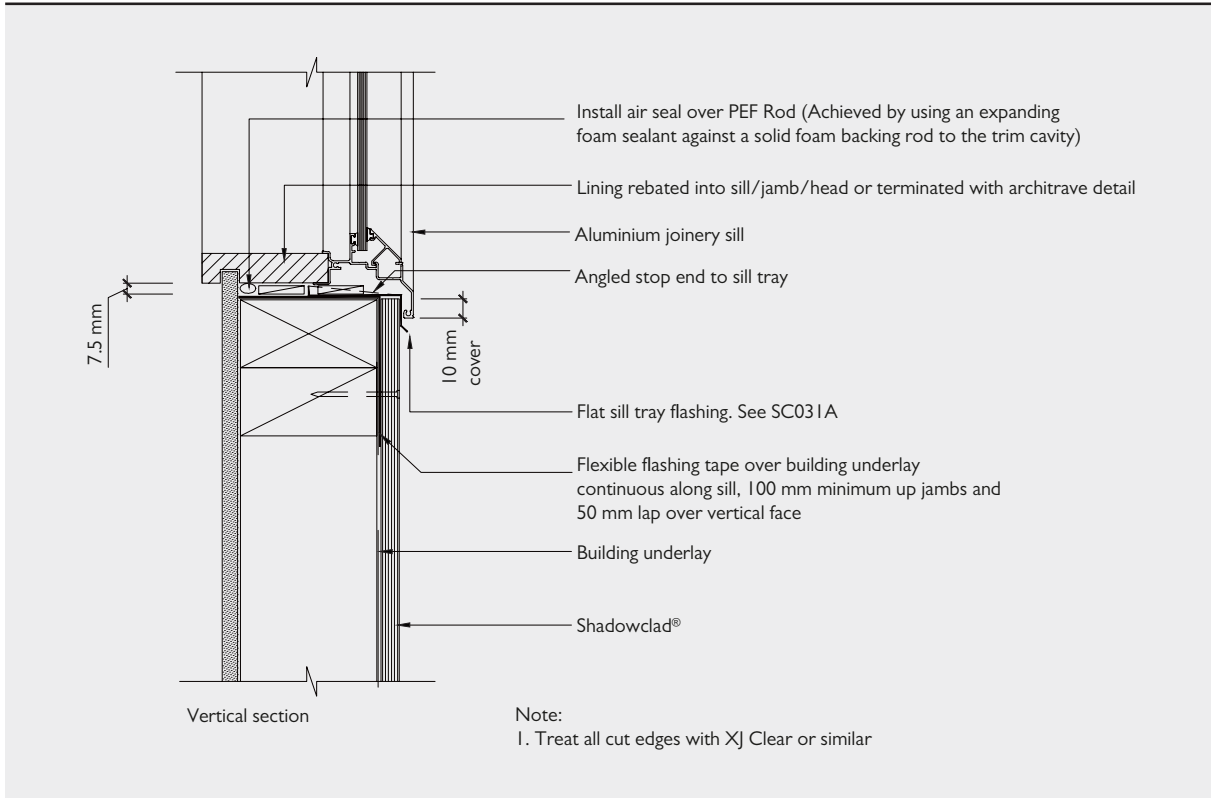

**SC03 I A: Shadowclad® General Window and Door Opening (Direct Fix)**

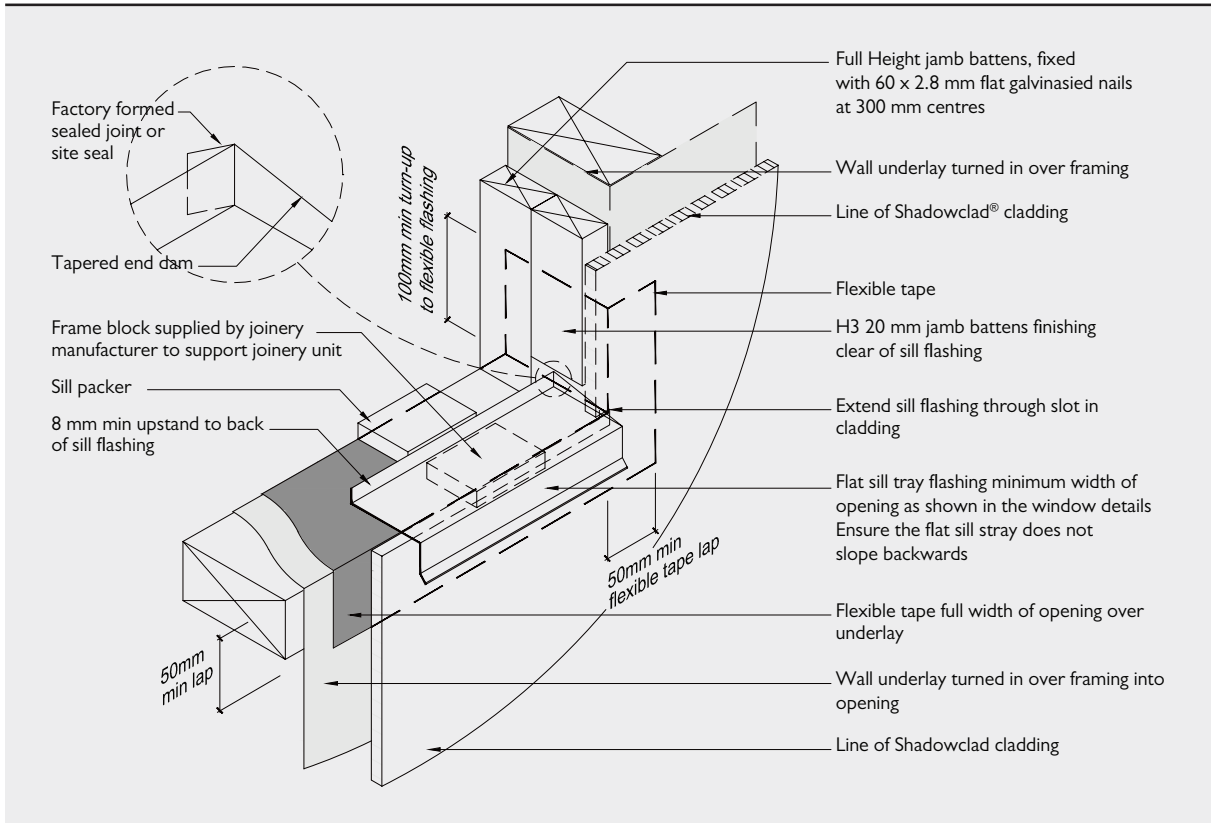

See important notice and warning on page 3.

## 4.15 WALL PENETRATIONS

### SC033A: Shadowclad® Meterbox Vertical Cross Section (Direct Fix)

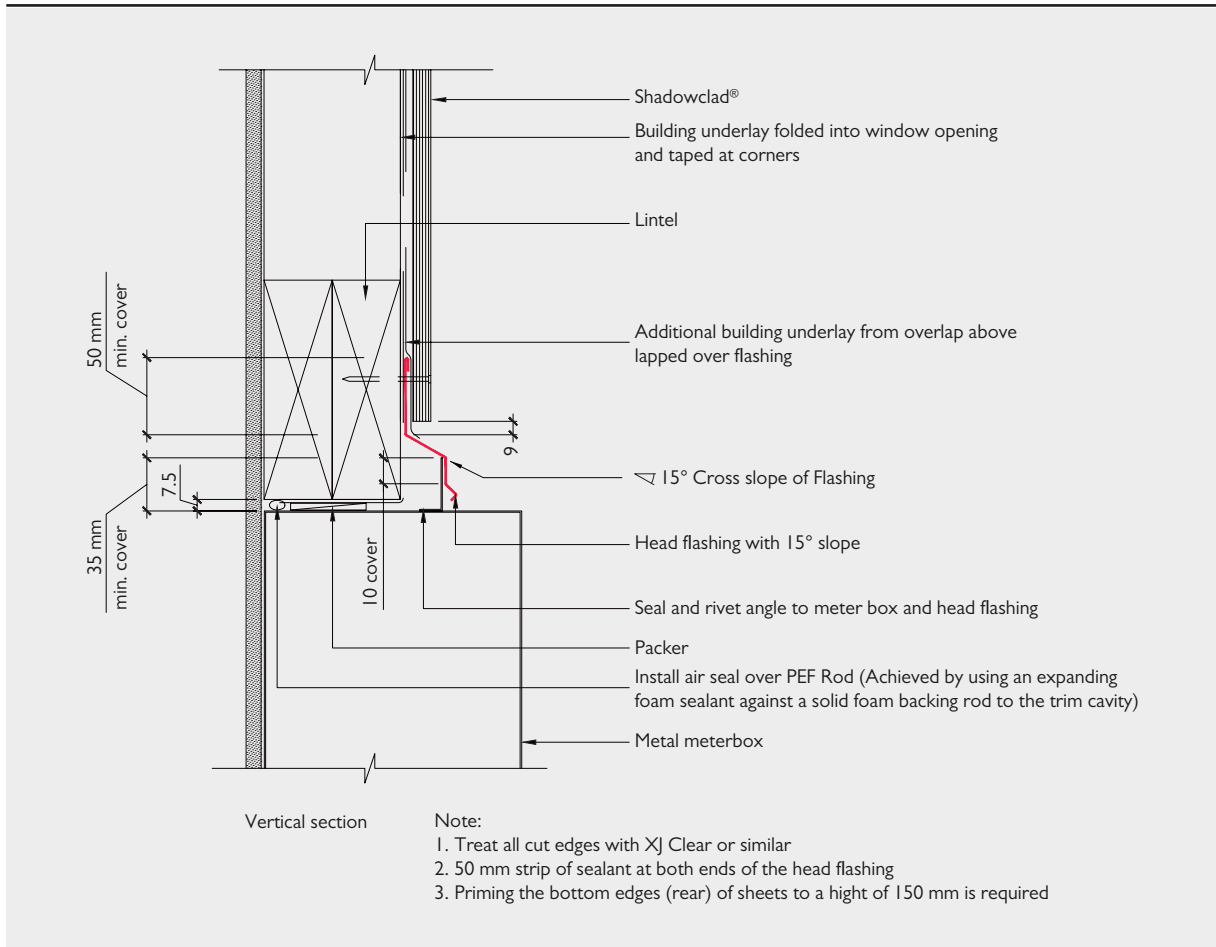

### SC033B: Shadowclad® Meterbox Horizontal Cross Section (Direct Fix)

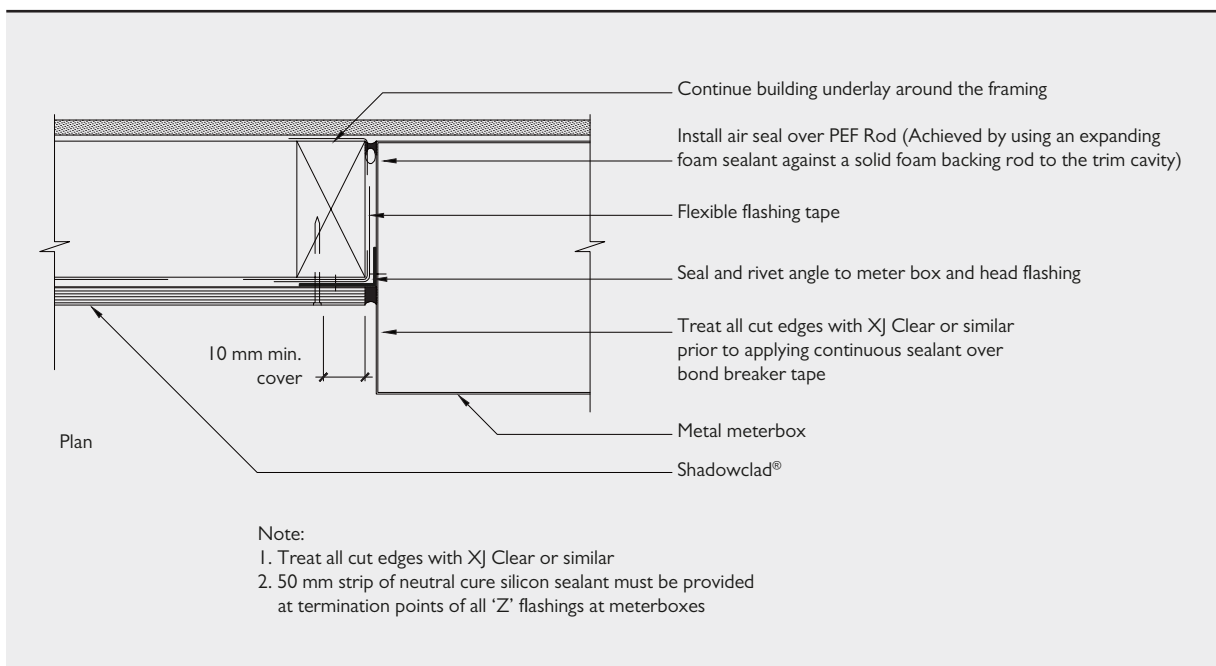

## SC035: Shadowclad® Soffit Detail (Direct Fix)

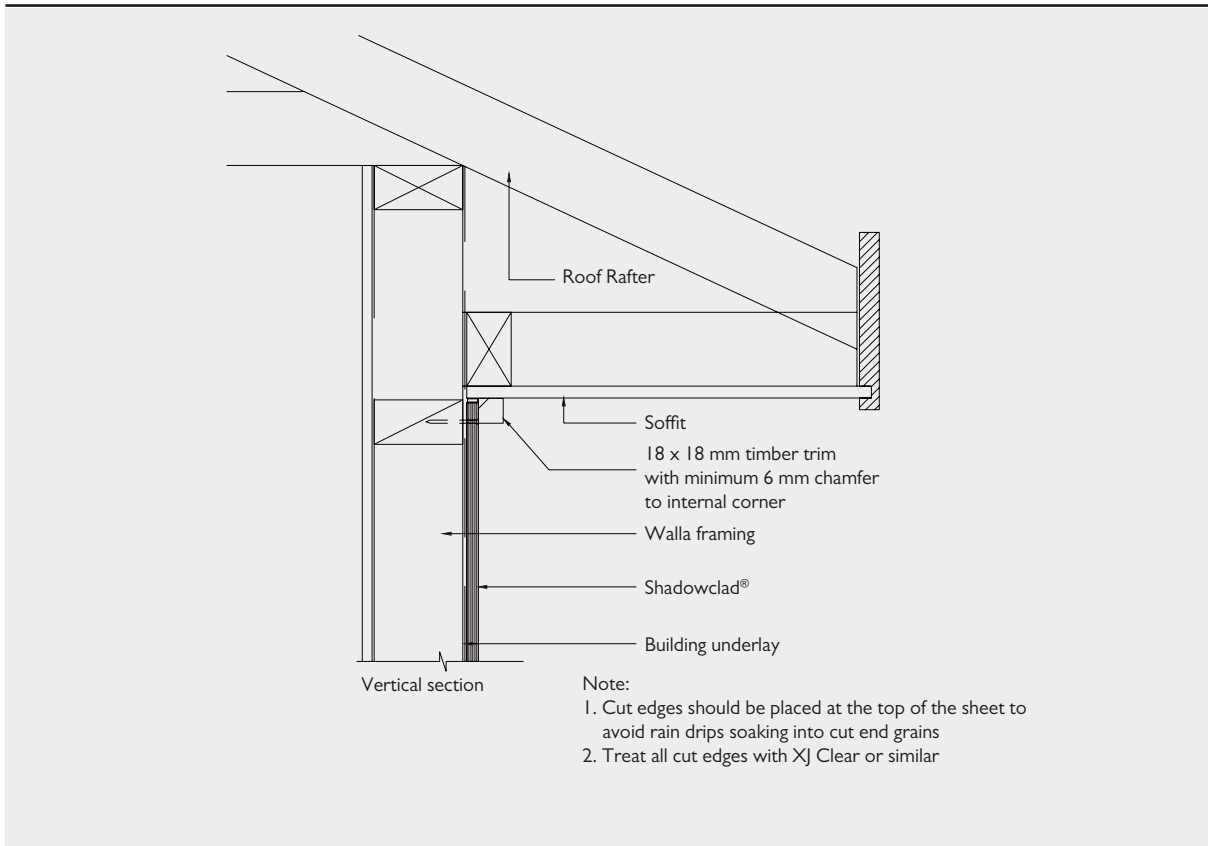

## SC035A: Shadowclad® Alternative Soffit Detail (Direct Fix)

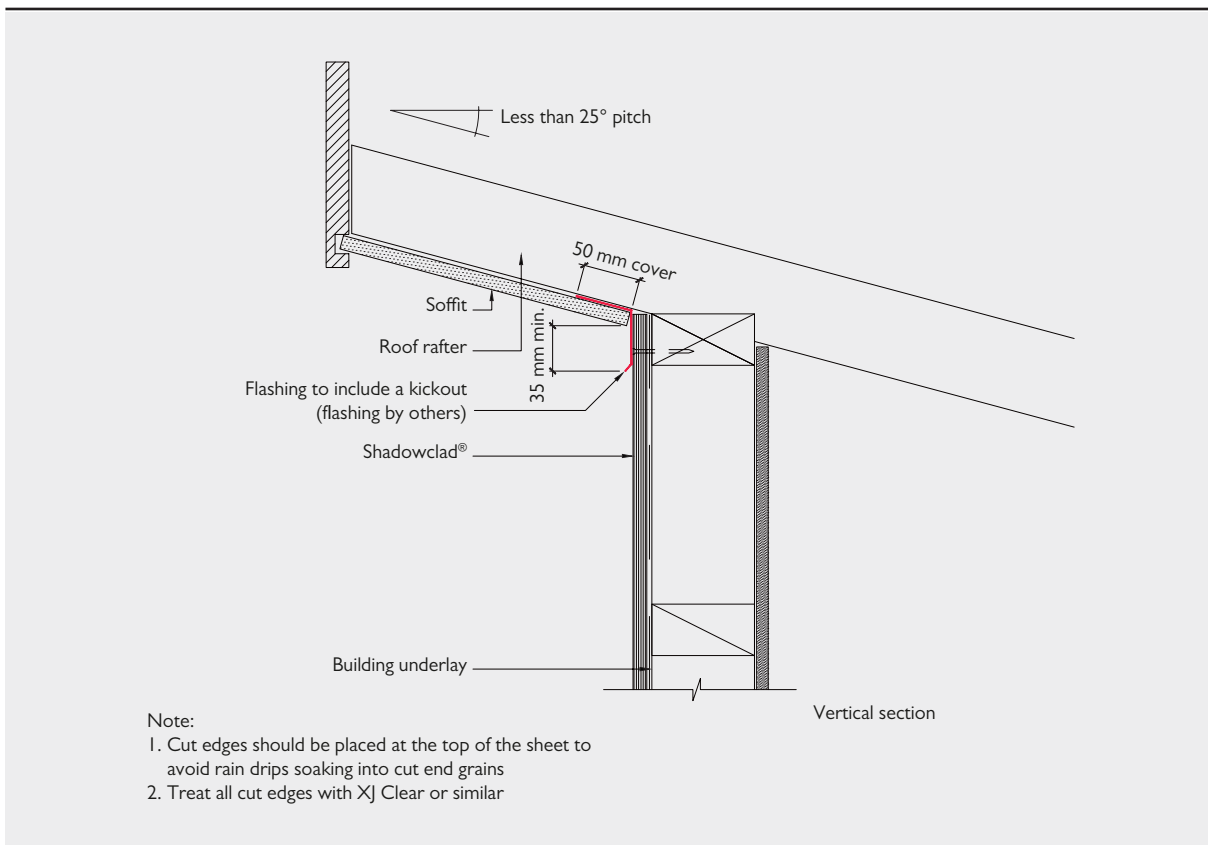

See important notice and warning on page 3.

SC037: Shadowclad® Alternative Soffit Detail (Direct Fix)

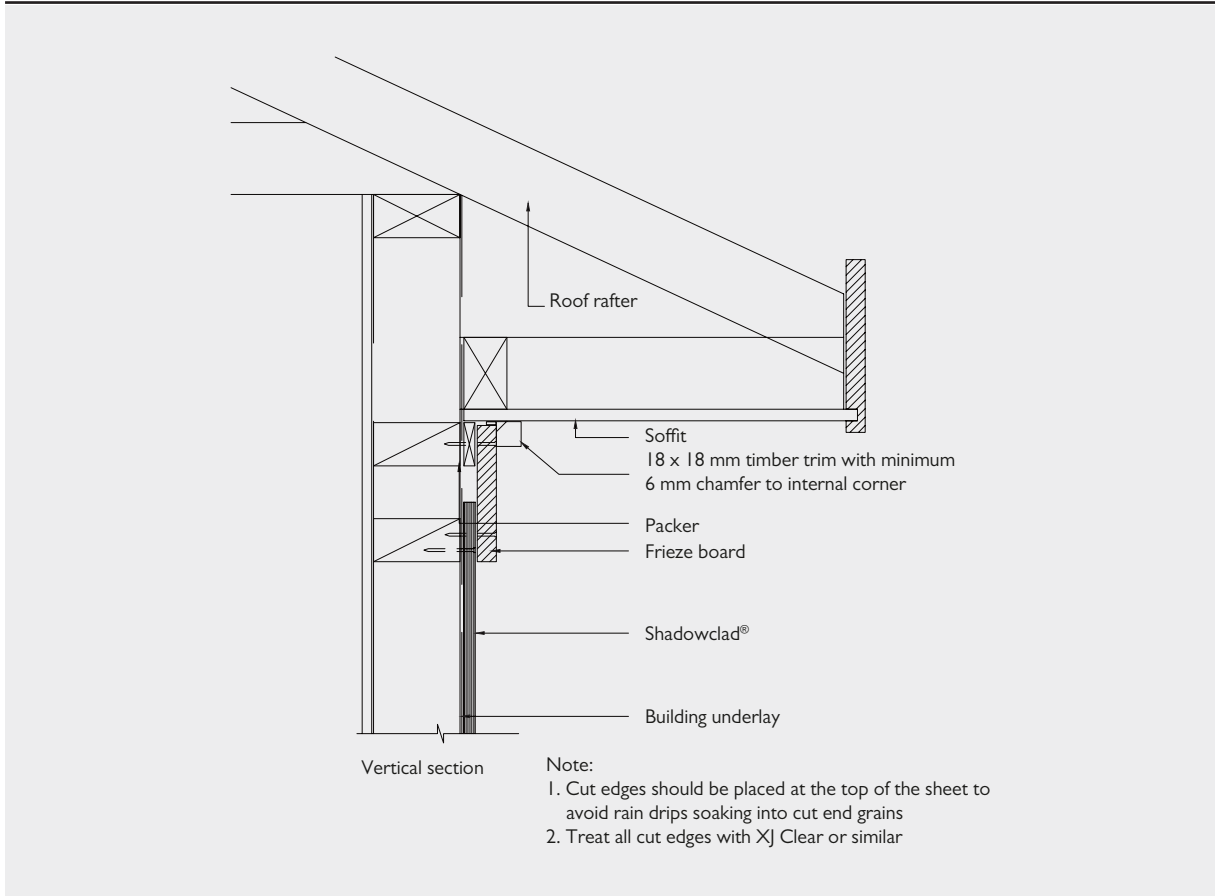

SC037A: Shadowclad® Alternative Soffit Detail (Direct Fix)

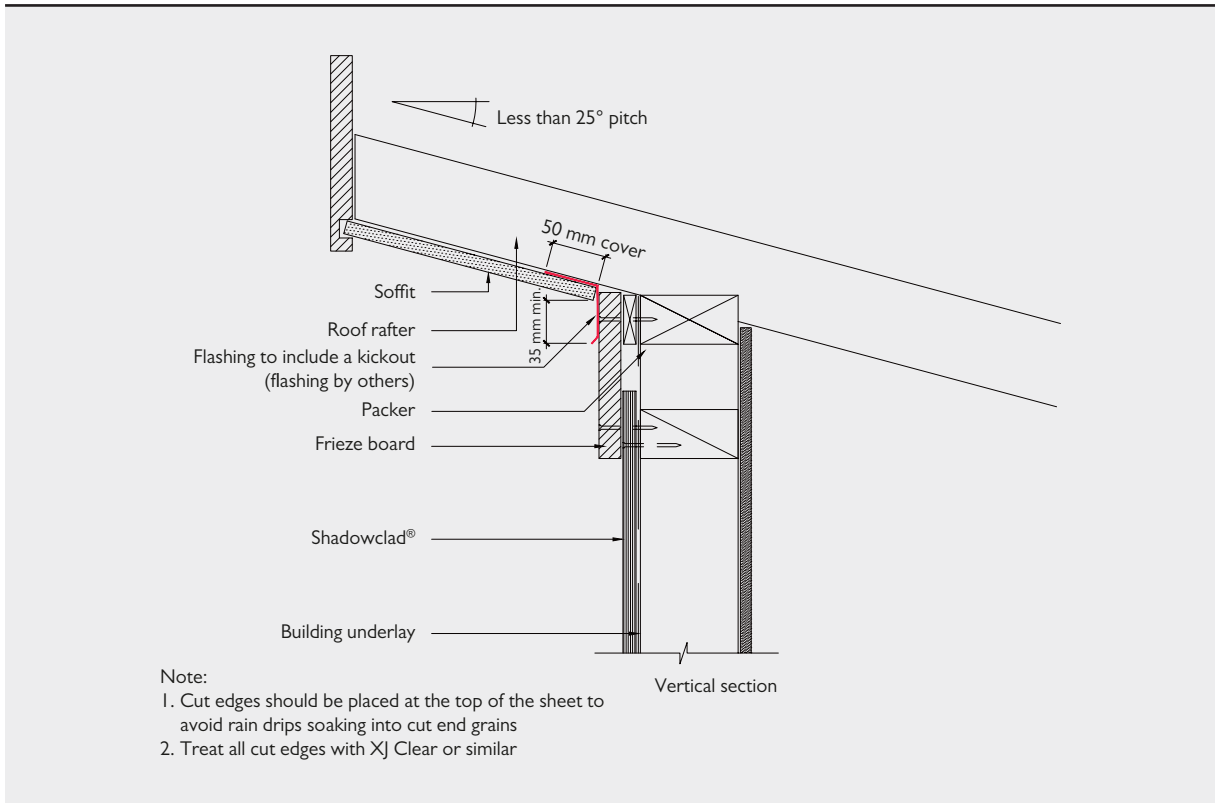



### SC039: Shadowclad® Pipe Penetration (Direct Fix)

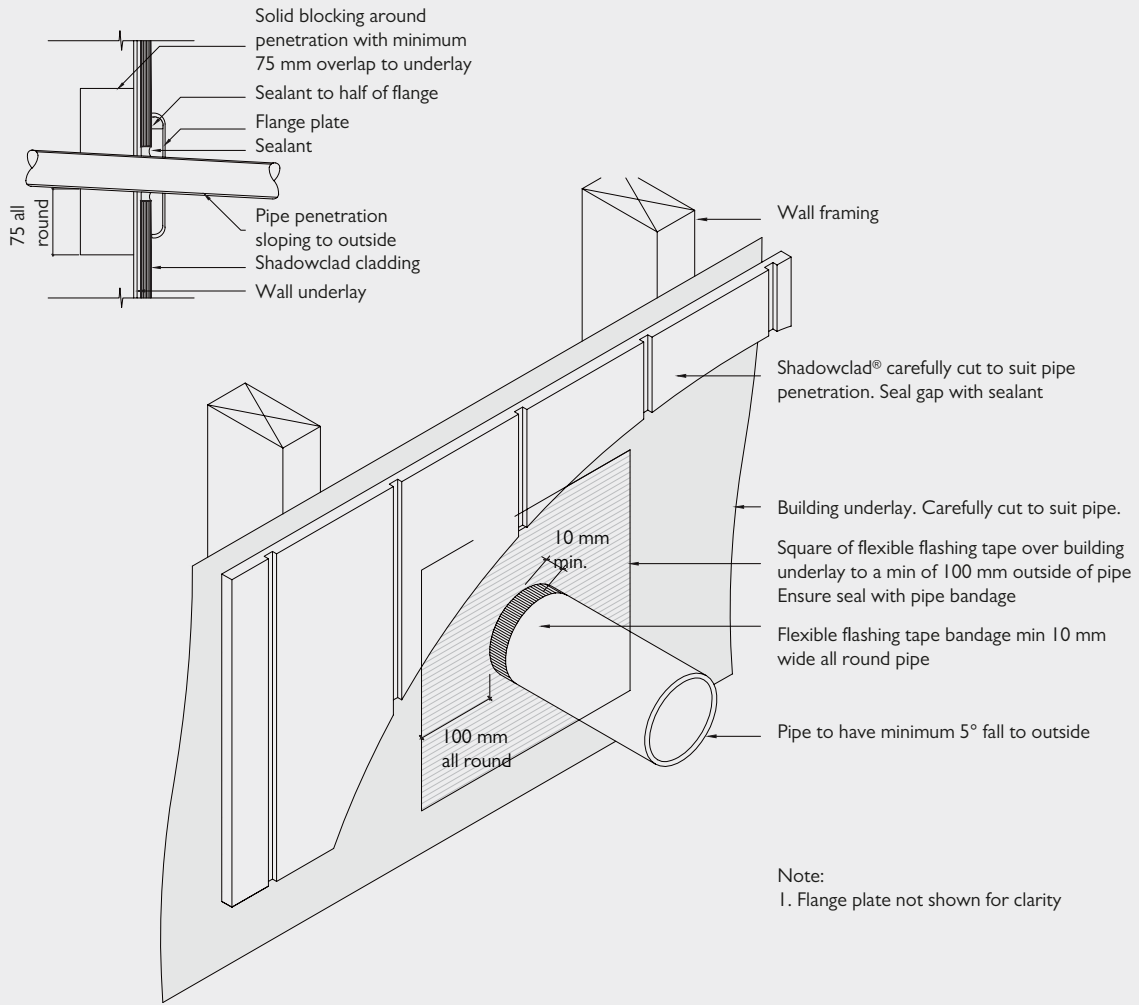

Note:  
1. Flange plate not shown for clarity

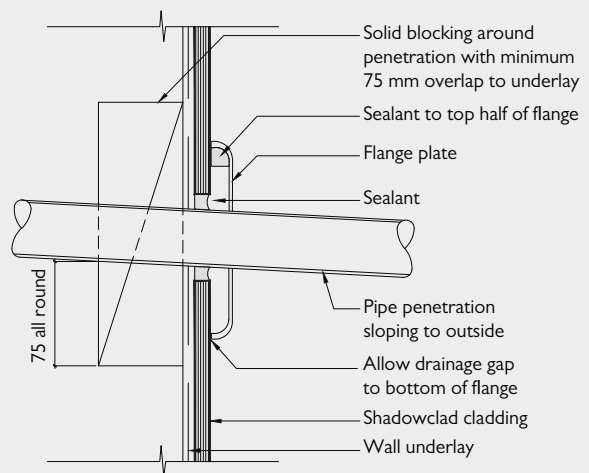

See important notice and warning on page 3.

## 4.16 SHEET CLEARANCES

### Ground Clearances

Shadowclad® must overhang the bottom plate on a concrete slab by a minimum of 50mm. The maximum distance from the bottom of the sheet to the fixing shall not exceed 75mm.

The bottom edge of the Shadowclad sheet must be a minimum of 50mm above decks and verandas, 100mm above paved ground and a minimum of 175mm above unprotected ground.

### SC041: Shadowclad® Overhangs and Ground Clearances (Direct Fix)

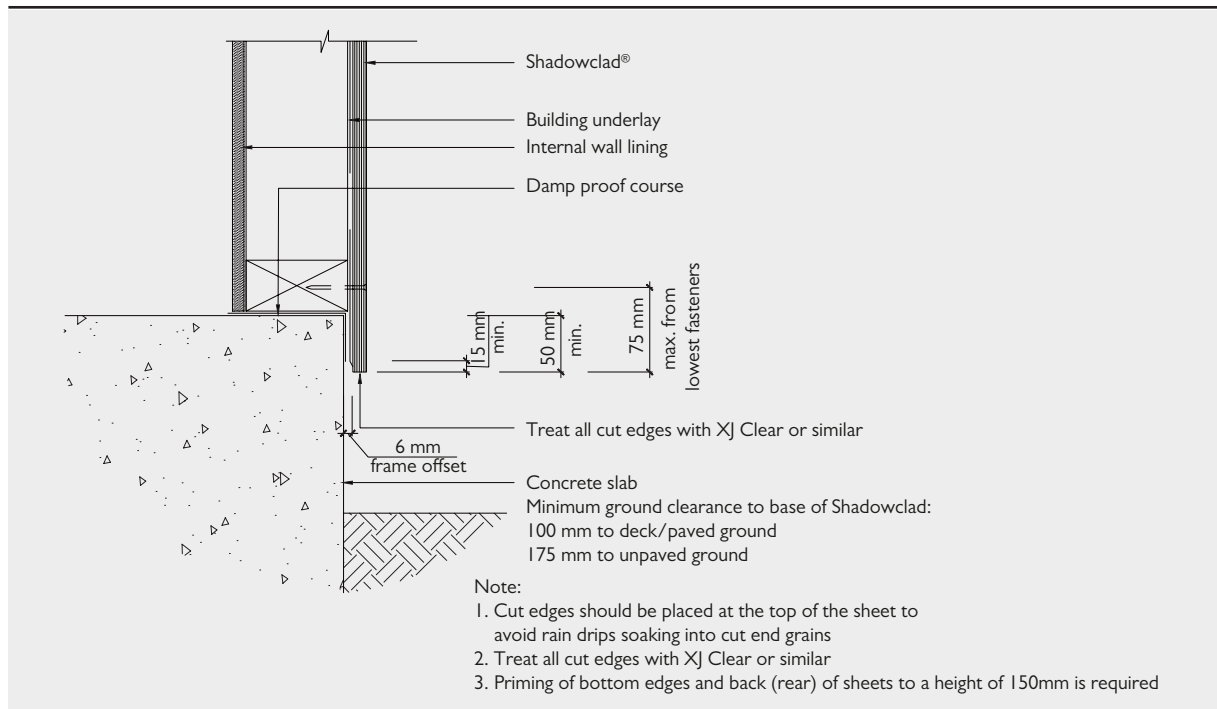

### SC043: Shadowclad® Upper Storey to Masonry Lower Storey (Direct Fix)

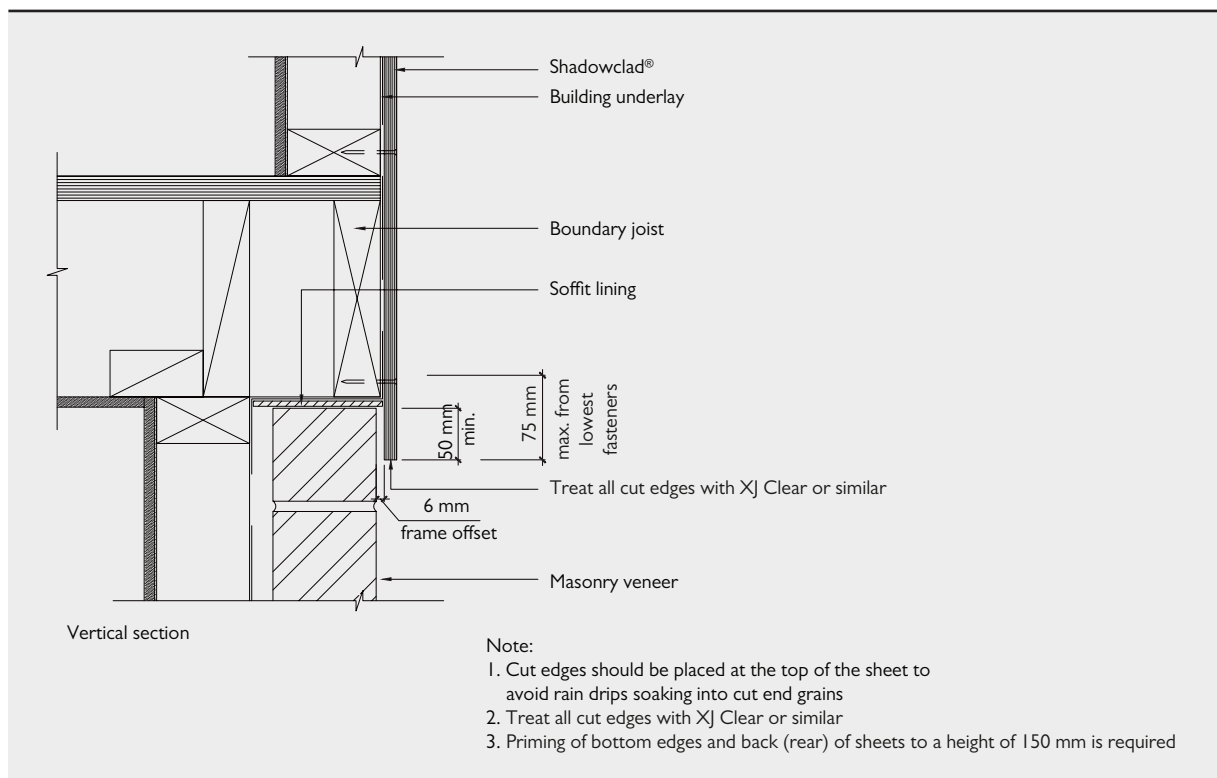





### 4.17 OTHER DETAILS

#### SC045: Shadowclad® Timber Ground Floor to Non-Cantilevered Deck (Direct Fix)

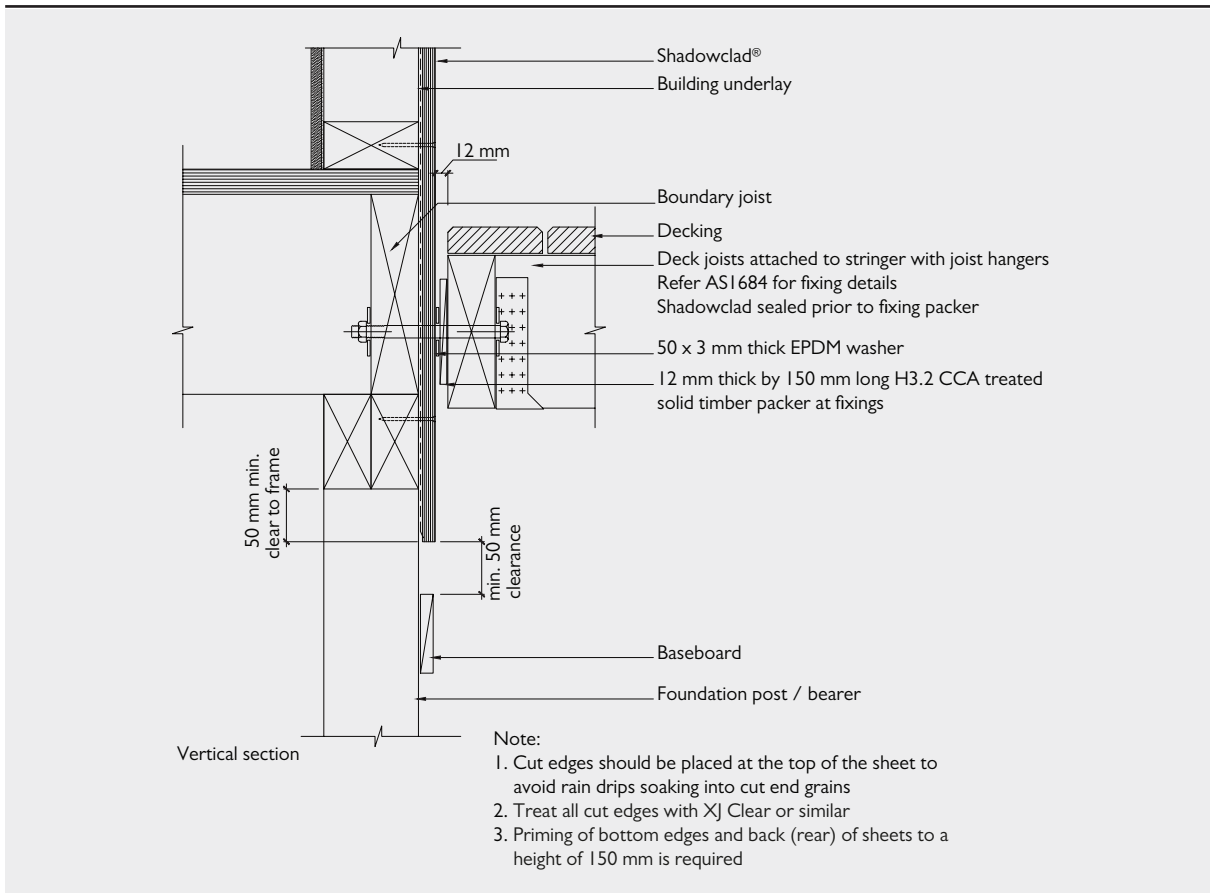

#### SC047: Shadowclad® Mid Floor to Non-Cantilevered Deck (Direct Fix)

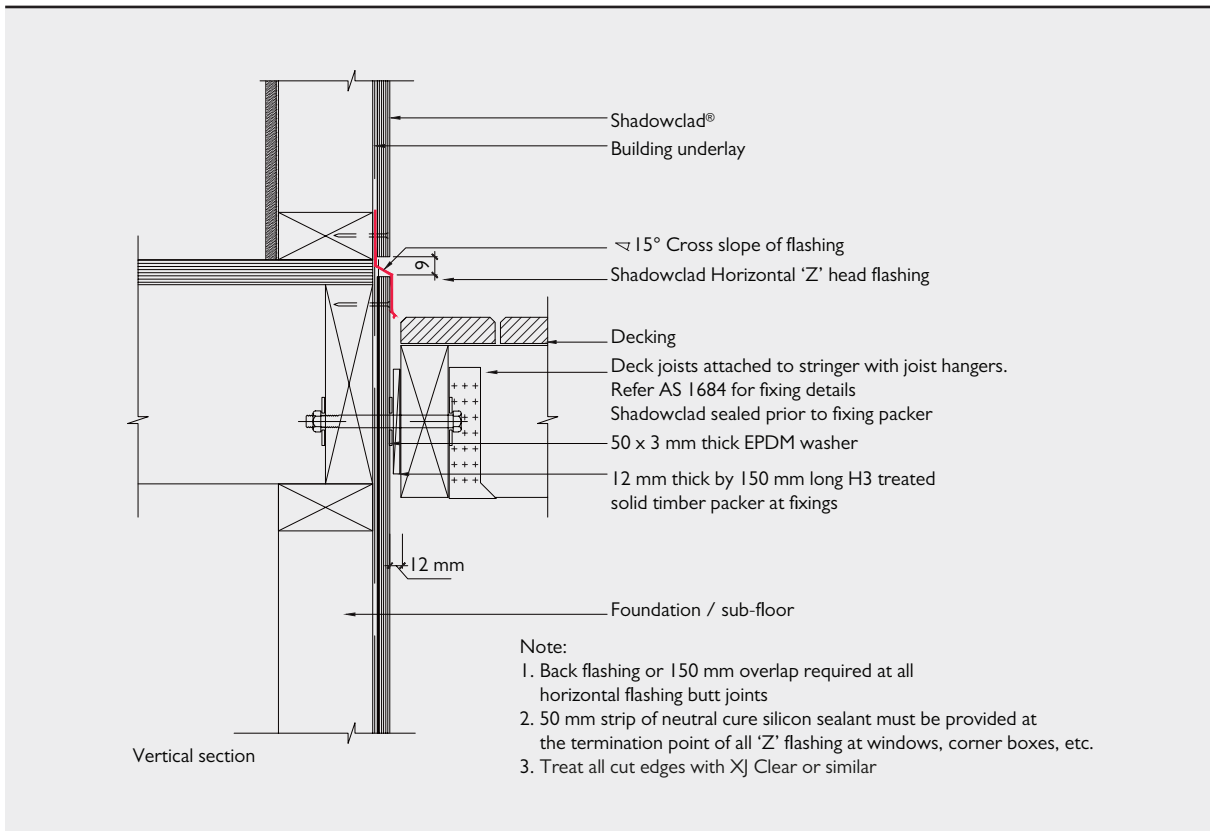

See important notice and warning on page 3.

## SC049: Shadowclad® Basic Apron Flashing (Direct Fix)

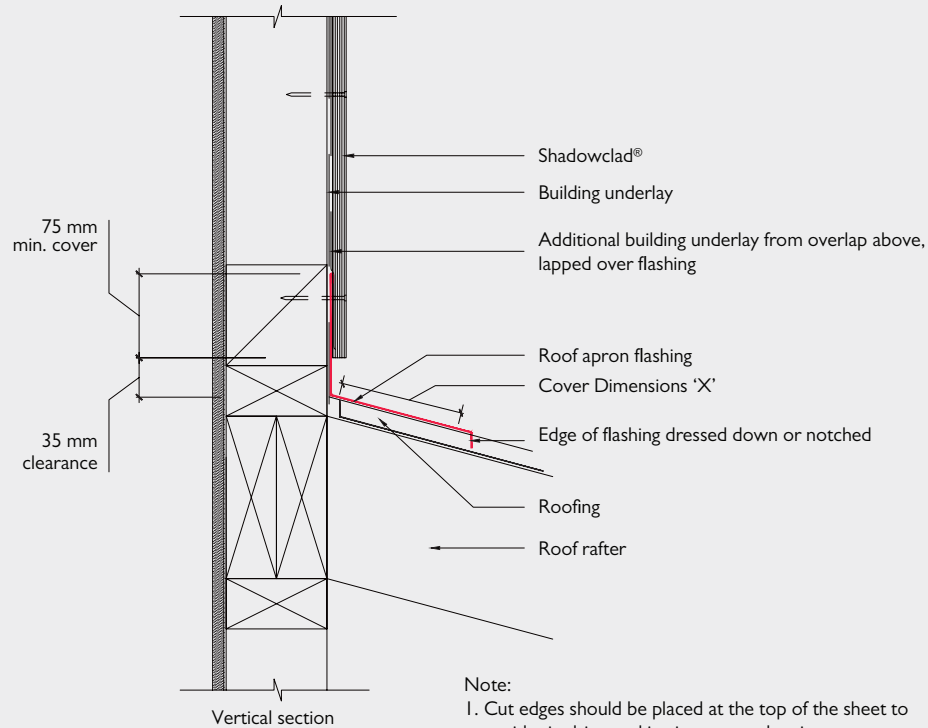

## Note:

1. Cut edges should be placed at the top of the sheet to avoid rain drips soaking into cut end grains
2. Treat all cut edges with XJ Clear or similar
3. Priming of bottom edges and back (rear) of sheets to a height of 150 mm is required

Cover Dimension 'X'	Roof Pitch	Wind Classification
130 mm	≥10	N1, N2
200 mm	All	N3, C1

## 5.0 COATING & APPLICATION – EXTERIOR CLADDING

### 5.1 SURFACE PREPARATION

- Shadowclad® is manufactured, treated and stored in dry conditions at CHH Plywood manufacturing facilities. The H3 treatment provides temporary repellence to mould prior to on site coating, however it remains the applicators responsibility to ensure the surface is dry and free from dust and mould prior to coating.
- If Shadowclad has been exposed to external weathering for over 3 months wash surfaces with a mild detergent solution to remove any dirt, dust, mould or sea spray prior to coating.
- If recoating, remove loose, flaking or unsound coatings and wash walls prior to recoating.
- The Shadowclad surface must be dry prior to applying any surface coating.

### 5.2 COATING APPLICATION

- If sheets feel greasy to touch, separate and place in a dry, well ventilated area to allow any residual solvents from the treatment process to flash off prior to applying coatings. **Shadowclad® is envelope preservative treated. Where sheets are cut, cut edges must be coated with a brush on timber preservative in accordance with the relevant manufacturer's instructions. XJ Clear, Arch Lonza Tanalised® Enseal Clear or Tanalised® Ecoséal is recommended. Failure to properly apply preservative to cut edges will negatively affect the durability of cut panels.**
- Coatings should be applied by brush to ensure adequate coating film build is achieved. Application via roller or spray is not recommended.
- Shadowclad Natural panels should be coated within 3 months of installation.
- Priming of sheet edges and on the rear of the sheet to a depth of 150mm is considered good practice, and required at the base of all sheets.
- A minimum total coating system film build of 90 microns is recommended when painting or using film forming stains, including a minimum 30 micron thickness per coat.
- For detailed advice on surface preparation, coating product suitability and general coating practice always refer to the coating manufacturer prior to application.

### 5.3 COATING SELECTION

The following coating information should be treated as a generic guide to coating systems typically used with Shadowclad exterior cladding. The selection, application and maintenance of coatings is the responsibility of building owners and the professionals that they engage. For advice on specific coating products and their suitability for use on Shadowclad always refer to the coating manufacturer.

It is important to note regardless of the cladding materials selected there will always be a level of coating maintenance required to ensure the cladding material is sufficiently protected from the elements and maintains the desired appearance.

#### Paints & Film Forming Stains

Three coats (1 undercoat, 2 top coats) of a good quality, 100% acrylic paint system with a light reflectance value (LRV) of 50% or greater (i.e. light colours) which is regularly maintained will provide the highest level of protection and durability for Shadowclad and is likely to require the least amount of coating maintenance over the life of the cladding.

Dark colours (LRV of below 50%) may still be used, however they are likely to increase heat and stress on the panel surface, reducing the panels overall lifespan and increasing the level of coating maintenance required to maintain an acceptable visual appearance.

Some film forming stains (i.e. coatings with the consistency of paint but with an appearance similar to penetrating stains) may offer similar protection qualities to paints however advice and

assurance should be sought from the coating manufacturer as to their suitability for use with Shadowclad prior to application.

Where paints or film forming stains are to be used, the use of Shadowclad Ultra is recommended. Shadowclad Ultra features a factory applied primer which in most cases eliminates the use of time consuming wet primers. (Refer Table 8).

Shadowclad Natural can also be used with paint however a conventional wet primer is required as part of the coating manufacturers overall system specification.

#### Penetrating Stains

Penetrating stains show the natural texture and character of timber and are widely used on Shadowclad exterior cladding.

Penetrating stains offer less protection for panels from exterior weathering than paints and film forming stains which are considerably thicker in surface film build. Due to their translucency, penetrating stains are likely to require additional coating maintenance during the panel's life to maintain an acceptable visual appearance.

Penetrating stains should only be used on Shadowclad Natural and are not recommended for use on Shadowclad Ultra.

CHH Plywood does not recommend the use of linseed oil based coating which have the potential to promote mould growth in this product.

**See important notice and warning on page 3.**

### Clear Coatings & Uncoated Shadowclad®

If Shadowclad® is left uncoated or is clear coated in exterior applications the long term aesthetics of the board will be significantly reduced. While the product will meet durability and weathertightness requirements a high visual appearance will not be achieved in the long term.

### Face Checking

Face checks are lengthwise separations of wood fibres in the face veneer of the plywood. They result from the normal swelling and shrinking of wood as it gains and loses moisture which is exacerbated by darker colours. It is important to realise that these checks are superficial, being confined to the face veneer. They do not alter the structural integrity of the plywood in any way. If you are the specifier, it is important to discuss these issues with your client before finalising colour choice. If checking occurs, repaint with a good quality, 100% acrylic exterior house paint in accordance with the manufacturer's instructions, thoroughly working paint into the face checks with a paint brush.

**Table 8: Coating System for Shadowclad® Ultra**

<b>Within 3 Months of Erection</b>	<b>Ensure the panel is clean and dry prior to top coating. Top coat with two coats of premium 100% acrylic exterior house paint.</b>
<b>OR</b>	
<b>Within 3 to 6 Months of Erection</b>	<b>Wash the surface with a mild detergent solution to remove any chalky material prior to top coating. Top coat with two coats of premium 100% acrylic exterior house paint.</b>

Note: For best results.

i/ allow 24 hours between coats.

ii/ use a light coloured paint system, LRV above 50%.

iii/ Recommend panel be washed down prior to painting to remove any sea salt spray or dirt deposits.

iv/ Minimum total coating film build of 90 microns is recommended, including a minimum 30 microns per coat.

## 5.4 COATING REQUIREMENTS IF RUN OFF IS USED FOR DRINKING WATER

Chemical manufacturers recommend that any run-off from treated surfaces should not be used for drinking water. Unsealed (e.g. unpainted) plywood claddings should not be used in situations where run-off directly from such claddings

is collected in water tanks for drinking water. Ensure selected coatings act as a sealer and refer to coating manufacturer's Safety Data Sheets to confirm specified coatings are suitable for use in these applications.

## 6.0 MAINTENANCE

All cladding materials, including Shadowclad®, require careful and regular product maintenance by the building owner throughout the cladding's normal service life to ensure long term durability and to maintain visual aesthetics.

### Claddings:

At a minimum, Shadowclad should be maintained by:

- Regularly washing it down (at least annually) with a mild detergent or solution to remove surface dirt, moss, mould, and sea spray.
- Inspect on at least a yearly basis paying particular attention to sheet joints, corners and bases.
- Keep dirt, soil or leaf build-up at least 150mm away from the base of panels.
- Clean spouting and downpipes as required, so that stormwater is not overflowing onto the cladding.
- Repaint as soon as the first sign of coating deterioration is identified in accordance with the coating manufacturer's specifications (including edges and sheet bottoms).
- Panel recoating requirements may vary depending on climate, orientation to the sun, coating type and coating colour selected.
- Maintain the exterior envelope and connections including joints, penetrations, flashings, heat pumps, and sealants that may provide a means of moisture entry beyond exterior cladding to comply with the performance requirements of the NCC 2016, Building Code of Australia - Volume Two.
- Prune back vegetation which is close to or touching the building as well as ensuring the aforementioned ground clearance requirements are maintained especially where gardens are concerned.
- **Do not** use water blasters to wash down the cladding.

### Flashings:

- Flashings should be periodically cleaned on a similar basis to the glass in windows.
- Clean Shadowclad flashings with a diluted solution of mild liquid detergent avoiding excessively hot solutions. Use a soft bristle brush. **Do not** use abrasive tools or cleaners on the coating.
- After cleaning, rinse thoroughly with fresh water. **Do not** use strong solvent type cleaners. Where the use of solvents is required, such as cleaning paint spills, use nothing other than methylated spirit. Ensure contact time is as short as possible, and rinse the solvent cleaner thoroughly from the surface with copious amounts of quality drinking water.
- Where cavity base closures are installed, ensure drainage holes are kept clear.

## 7.0 FREQUENTLY ASKED QUESTIONS

**Q:** Where can Shadowclad® be used?

**A:** Shadowclad can be used as an exterior cladding and is H3 treated for this purpose. We recommend the use of Shadowply for internal lining applications (moisture free areas only). Shadowply is an untreated plywood panel specifically designed for dry internal applications.

**Q:** Do I have to re-treat cut edges of Shadowclad panels?

**A:** H3 treated Shadowclad is envelope preservative treated. All cuts made in treated plywood **must** have a brush on preservative treatment applied fully to the cut area. CHH Plywood recommends the use of Protim® Solignum® XJ Clear Timber Protective (XJ Clear), Arch Lonza Tanalised® Enseal Clear or Tanalised® Ecoséal.

**Q:** When used as a cladding what are the durability expectations of Shadowclad?

**A:** Under the ABCB guidelines document, Durability in Building Shadowclad (when used as an exterior cladding) is required to meet a 15 year minimum durability level.

To achieve a 15 year durability Shadowclad must be:

- H3 preservative treated.
- Coated with a good quality penetrating stain, film forming stain or paint system.
- Uncoated Shadowclad will meet the durability and weathertightness requirements, but a high visual appearance will not be achieved in the long term.
- Coatings must be regularly maintained as part of a normal building maintenance program throughout the life of the building.

**Q:** Can Shadowclad, when used as an exterior cladding, be coated in dark colours?

**A:** Dark colours (coatings with an LRV of below 50%) will achieve a 15 year durability however customers must expect an increased level of recoat and general product maintenance compared to where light coating colours are used.

The greatest level of cladding protection and least amount of coating maintenance can be achieved by using a good quality paint system (applied as per the coating manufacturers specifications) with an LRV of 50% or greater and a minimum total coating system film build of 90 microns, including a minimum 30 micron thickness per coat.

For further information on coatings always refer to the applicable coating manufacturer's specification material.

**Q:** In the Shadowclad exterior flashing range can I colour the flashings to match the colour of my building?

**A:** Shadowclad aluminium flashings are available in either anodised or mill finishes. Anodised flashings are silver in colour and can be installed immediately. Mill finished flashings can be powder coated to specific colours by the customer.

**Q:** Does face checking affect the performance of Shadowclad?

**A:** Face checks are lengthwise separations of wood fibres in the face veneer of the plywood. They result from the normal swelling and shrinking of wood as it gains and loses moisture which is exacerbated by darker colours. These checks are superficial, being confined to the face veneer. They do not alter the structural integrity of the plywood in any way.

**Q:** Where can I download the Shadowclad Installation APP?

**A:** The Shadowclad Installation APP can be downloaded from [www.shadowclad.com.au](http://www.shadowclad.com.au) or the respective device APP procurement marketplace.

**Q:** Where can I get a Shadowclad Stick from?

**A:** Shadowclad Sticks may be ordered by contacting CHH Plywood direct by phoning 1 800 338 463, ordering via the Shadowclad APP or requesting on the Shadowclad website: [www.shadowclad.com.au](http://www.shadowclad.com.au).

## 8.0 GLOSSARY OF TERMS

**Sealant:** A flexible neutral cure sealant for filling of spaces/ gaps and weatherproofing that is for exterior use. It is the designers' and builders' responsibility to ensure that sealants are fit for purpose and compatible with Shadowclad® products and any other building materials or components used within the Shadowclad installation.

**Air Seal:** A continuous seal fitted between a window or door reveal and the surrounding wrap and associated tape enclosing wall framing to prevent the flow of air into the building interior. Air seal must be weathertight so that moisture is not able to access the structure.

**Foam Bond Breaker:** A tape that is polyethylene backed that prevents "3-Point" adhesion mating surfaces that ensures that the sealant only attaches to two surfaces (and not the third which would create an anchor point preventing the sealant moving as it is designed to).

**PEF Rod:** A foam formed polyethylene "noodle" that is designed to be inserted between two surfaces. Should have a 25-33% larger diameter than the gap/space you are inserting it into.

**Protim® Solignum® XJ Clear or Similar:** A supplementary preservation treatment that preserves the treatment envelope of timbers with a Class H3 and above.

## 9.0 REFERENCES & SOURCES OF INFORMATION

- National Construction Code series 2015 - Volume two.
- AS/NZS 2269:2012 "Plywood Structural".
- AS/NZS 1604.3:2010 "Specification for Preservative Treatment, Part 3: Plywood".
- AS/NZS 4284:2008 "Testing of Building Facades".
- AS 1720.1:2010 "Timber Structure Standard : Design".
- AS 1684.2:2010 Non Cyclonic Areas.
- AS 3715:2002 "Metal Finishing – Thermoset powder coating for architectural application of aluminium and aluminium alloys".
- Safety Data Sheet.
  - SDS Shadowclad Azole Treated Plywood.
  - SDS Stainless Steel flashings.
  - SDS Aluminium flashings.
  - SDS Shadowclad Ultra LOSP Pre-primed Treated Plywood.
- APA ([www.buildabetterhome.org](http://www.buildabetterhome.org)).
- EWPAA ([www.ewp.asn.au](http://www.ewp.asn.au)).

Standards can be purchased online at <https://infostore.saiglobal.com/store/>.

NCC 2016, Building Code of Australia - Volume Two can be downloaded free of charge at [www.services.abcb.gov.au/NCCOnline](http://www.services.abcb.gov.au/NCCOnline).

Line drawings within this literature can be downloaded from [www.shadowclad.com.au](http://www.shadowclad.com.au).

## 10.0 LIMITATIONS

The information contained in this document is current as at September 2018 and is based on data available to CHH Plywood at the time of going to print.

All photographic images are intended to provide a general impression only and should not be relied upon as an accurate example of Shadowclad products installed in accordance with this document or BCA compliance documents.

This publication replaces all previous CHH Plywood design information and literature relating to Shadowclad structural plywood products and flashings. CHH Plywood reserves the right to change the information contained in this document without prior notice. It is your responsibility to ensure that you have the

most up to date information available, including at the time of applying for a building consent. You can call 1800 338 463 or visit [www.shadowclad.com.au](http://www.shadowclad.com.au) to obtain current information.

**CHH Plywood has used all reasonable endeavours to ensure the accuracy and reliability of the information contained in this document. However, to the maximum extent permitted by law, CHH Plywood assumes no responsibility or liability for any inaccuracies, omissions or errors in this information nor for any actions taken in reliance on this information.**



# SHADOWCLAD® KEY INSTALLATION & DESIGN POINTS

## EXTERIOR CLADDING APPLICATIONS

The following tasks are provided to installers to point out key installation and design factors when used as an exterior cladding. These do not detract from the requirements to read and understand this literature as a whole.

Task	Tick when checked
<b>Prior to Specification and Installation</b>	
Read the Shadowclad® Specification and Installation Guide in its entirety	<input type="checkbox"/>
<b>Framing Plan</b>	
Framing setout drawings to suit Shadowclad fixing and installation guidelines	<input type="checkbox"/>
<b>Sheet Cuts</b>	
Coat all sheet cuts with a preservative timber treatment such as XJ Clear, or similar	<input type="checkbox"/>
After applying the timber preservative treatment, apply the surface coating (e.g. paint or stain) to cut edges	<input type="checkbox"/>
Place uncut edge to bottom	<input type="checkbox"/>
<b>Fastener Material Type</b>	
Galvanised fasteners or better used (Stainless steel annular groove nails required in sea spray zones)	<input type="checkbox"/>
<b>Sheet Fastener Pattern</b>	
Around sheet edge – maximum 150mm centre spacing	<input type="checkbox"/>
Within sheet body – maximum 300mm centre spacing	<input type="checkbox"/>
<b>Horizontal Sheet Joints</b>	
Minimum 9mm separation gap between sheets above all Horizontal 'Z' flashings	<input type="checkbox"/>
Prime the bottom of the sheet edge and 150mm up the back (rear) of the sheets	<input type="checkbox"/>
50 mm strip of neutral cure silicon sealant at all 'Z' flashing terminations excluding terminations at Shadowclad metal corner flashings	<input type="checkbox"/>
Back flashings or 150mm overlap to all flashing butt joints	<input type="checkbox"/>
<b>Expansion Gaps Between Sheets (Vertical Sheet Joints)</b>	
Texture Profile Sheets - 2mm gap between vertical edges of sheets	<input type="checkbox"/>
Groove Profile Sheets - 9mm gap (i.e. full groove space) between vertical edges of sheets	<input type="checkbox"/>
Note: Expansion gaps required between vertical edges of sheets to accommodate natural expansion and contraction of sheets	
<b>Ground Clearances</b>	
Paved/Sealed Ground - minimum 100mm distance from the ground to sheet bottom	<input type="checkbox"/>
Broken Ground - minimum 175mm distance from the ground to sheet bottom	<input type="checkbox"/>
Apply the surface coating on the sheet edge and 150mm up the rear of the back of the sheet	<input type="checkbox"/>

Refer to the current Shadowclad® Specification and Installation Guide for full installation specifications and suggested details.

See important notice and warning on page 3.



## NCC 2019 AMENDMENT

### TECHNICAL NOTE

#### **Shadowclad® Specification and Installation Guides dated September 2018 and the National Construction Code Series 2019, Volume 2, Amendment 1.**

This technical note addresses the changes to the National Construction Code Series 2019 and the September 2018 Shadowclad Literature. Carter Holt Harvey Plywood Ltd (CHH Ply) have reviewed the Shadowclad Specification and Installation Guides in relation to current references to the NCC 2016, Volume 2 and the compliance pathways relative to the National Construction Code Series 2019, Volume 2, Amendment 1 (NCC 2019, Building Code of Australia - Volume Two Amendment 1).

CHH Ply can confirm that where the September 2018 dated Specification and Installation Guides for Shadowclad for cavity wall construction and Shadowclad for direct fix cladding, the references to NCC 2015, Building Code of Australia Volume 2, can be directly replaced with NCC 2019, Building Code of Australia - Volume Two Amendment 1.

Where the Shadowclad product range is installed in accordance with the September 2018 Direct fix or Cavity wall construction Specification and Installation Guides will meet the performance requirements of the NCC 2019 Building Code of Australia – Volume 2 as detailed in section 2.3, code compliance, of the applicable Shadowclad literature.

For further information please contact CHH Ply on 1800 338 463 or visit [shadowclad.com.au](http://shadowclad.com.au).

### REFERENCES

NCC 2019, Building Code of Australia - Volume Two Amendment 1  
Shadowclad for Cavity wall construction – September 2018  
Shadowclad for Direct fix cladding – September 2018

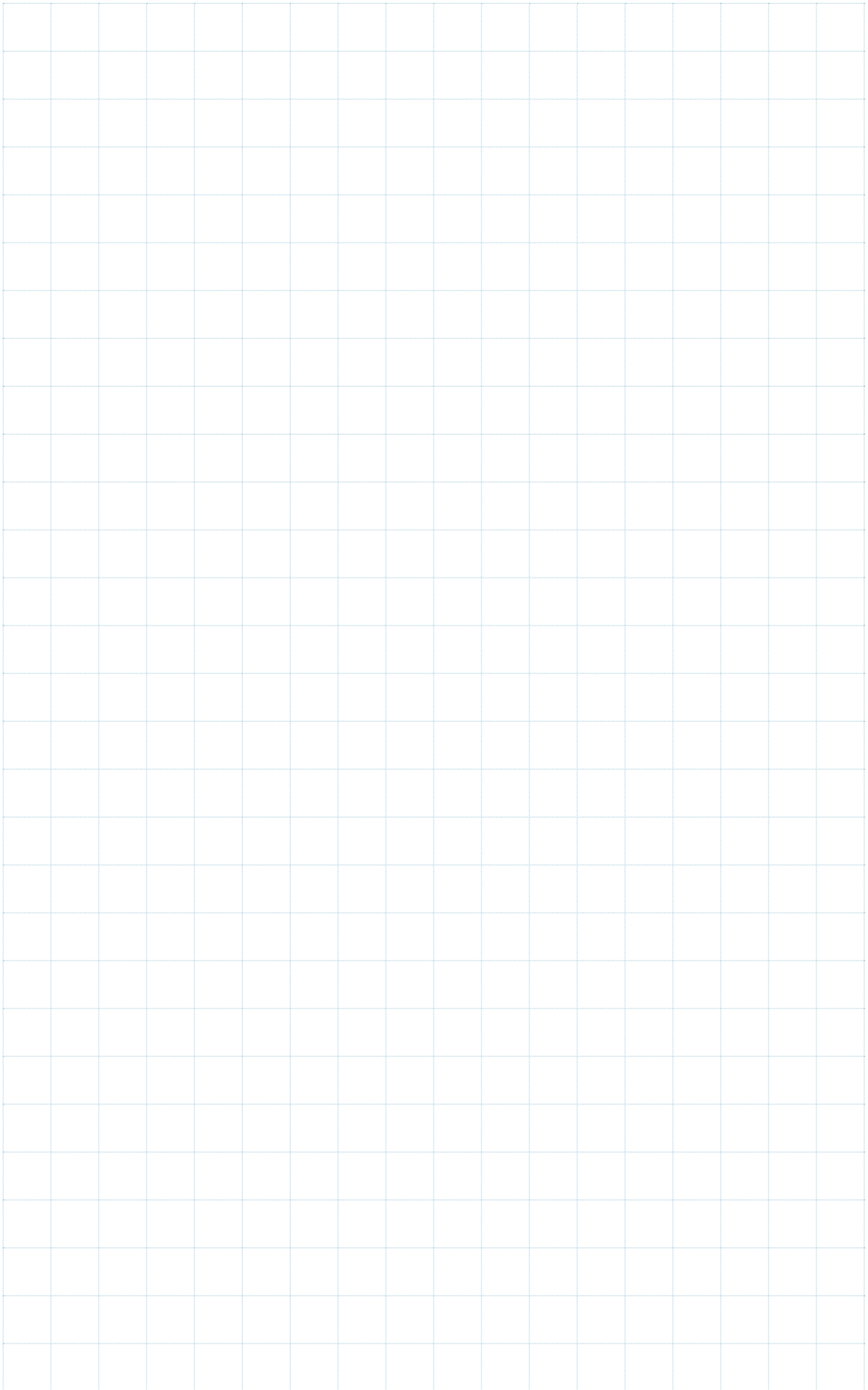

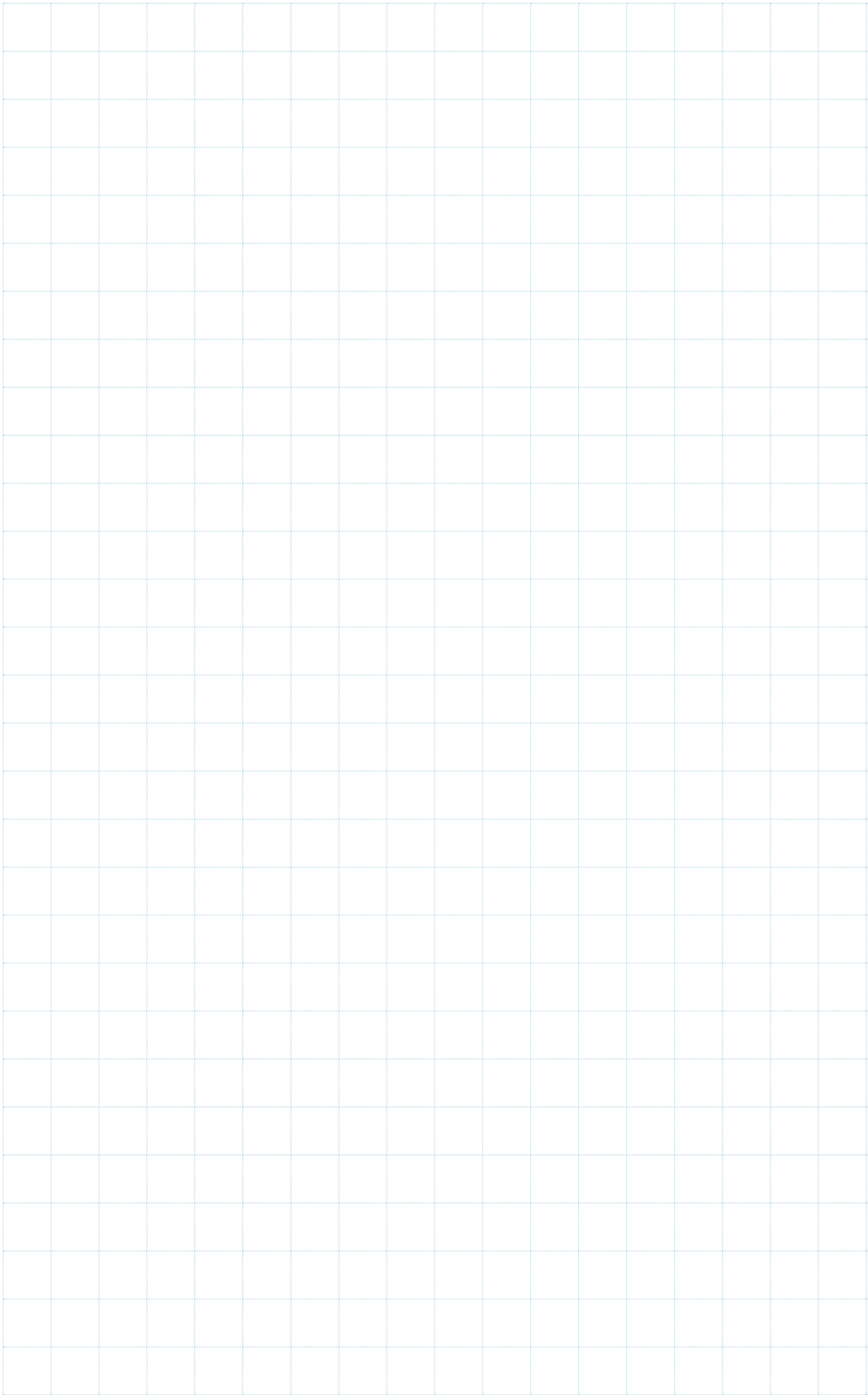

# shadowclad®

 **CarterHoltHarvey**  
**Plywood**

Phone: 1800 338 463  
[www.shadowclad.com.au](http://www.shadowclad.com.au)

September 2018

